

CARLIFT



CARLIFT II 4.0

Four Post Lift

Original Operating Instructions

BA363101-en

Contents

1	Safety	5
1.1	Introduction.....	5
1.2	Symbols.....	5
1.3	Intended Use	5
1.4	Safety Instructions for Commissioning	5
1.5	Safety Instructions for Operation.....	5
1.6	Safety Instructions for Servicing.....	6
1.7	Safety Features	6
1.8	Safety Instructions for Handling Hydraulic Fluid.....	7
1.9	What to Do in the Event of Defects or Malfunctions	7
1.10	What to Do in the Event of an Accident	7
2	Description	8
2.1	General Information	8
2.2	Sample Nameplate.....	8
2.3	Specifications.....	9
3	Transport and Storage	12
4	Installation and Initial Operation	12
5	Operation	12
5.1	Requirements on the Operator	12
5.2	Main Switch	12
5.3	Controls	13
5.4	Using Support Blocks	14
5.4.1	Stacking Two Blocks on Top of Each Other	17
5.5	Raising.....	17
5.6	Lowering	17
5.7	Wheel Alignment	18
5.8	Lighting	18
5.9	Wheel-Free Jack (Optional).....	19
5.10	Manual Lowering.....	19
5.10.1	Manual Lowering of Lift	19
5.10.2	Manual Lowering of Wheel-Free Jack.....	21
6	Maintenance	22
6.1	Maintenance Schedule	22
6.2	Annual Inspection.....	22
6.3	Checking the Fluid Level.....	23

6.4	Greasing the Slide Tracks.....	23
6.5	Inspecting the Wire Ropes	24
6.6	Care Instructions.....	25
6.7	Troubleshooting.....	25
6.8	Spare Parts.....	25
7	Service Lifetime.....	26
8	Dismantling.....	26
9	Disposal.....	26
10	Contents of the Declaration of Conformity.....	26
11	Company Information.....	27

1 Safety

1.1 Introduction

Thoroughly read this manual before operating the equipment and comply with the instructions. Always display the manual in a conspicuous location.

Personal injury and property damage incurred due to non-compliance with these safety instructions are not covered by the product liability regulations.

1.2 Symbols



Important safety instructions. Failure to comply with instructions could result in personal injury or property damage.



Important information.

1.3 Intended Use

- This lift shall be used exclusively for the safe lifting of motor vehicles. Observe the rated load capacity.
- The lift shall not be modified without the express written consent of the manufacturer. In case of non-compliance the declaration of conformity becomes void.

Any use other than described is inappropriate, for example:

- Climbing on the lift supports
- Transporting persons on the lift supports
- Usage as mobile work platform or for other lifting operations

1.4 Safety Instructions for Commissioning

- The lift shall be installed and commissioned by authorized service personnel only.
- The control desk shall not be installed in the danger zone of the lift.
- The standard lift version shall not be installed and commissioned in hazardous locations, outdoors, in moist rooms (e.g. car wash) or outside a temperature range of 0...40 °C.

1.5 Safety Instructions for Operation

- Drive on the lift only when it is in bottom position.
- Ensure an unobstructed movement of lift and vehicle.
- After raising the vehicle briefly, stop and check the lift supports for secure contact with the vehicle.

- Make sure the vehicle doors are closed during raising and lowering cycles.
- Closely watch lift and vehicle during raising and lowering cycles.
- Do not allow anyone to stay in lift area during raising and lowering cycles.
- Do not allow anyone to climb on lift or inside raised vehicle.
- Comply with the applicable accident prevention regulations.
- Do not exceed the rated load capacity as indicated on the lift nameplate.
- Only use the vehicle manufacturer's recommended lift points.
- Do not use the lift for transporting persons.
- Lifts with runways: After positioning the vehicle on the lift secure it against roll-off.
- Keep lift and vehicle free of tools and parts.
- Lifts with support arms: Use caution when removing or installing heavy components. Center-of-gravity displacement may occur. Secure the vehicle using lashing straps.
- Keep the lift and lift area clean. Slip hazard on oily surface!
- The main switch serves as emergency switch. In case of emergency turn it to position "0".
- Protect all parts of the electrical equipment from humidity.
- Protect the lift against unauthorized usage by padlocking the main switch.
- Use caution with operating vehicle engines. Danger of poisoning!

1.6 Safety Instructions for Servicing

- Service work must be done by authorized service technicians.
- Turn off and padlock the main switch before doing any repair, maintenance or setup work.
- The system must be unpressurized during maintenance work.
- Work on pulse generators or proximity switches must be done by authorized service technicians.
- Work on the electrical equipment must be done by service technicians or qualified electricians.
- Ensure that ecologically harmful substances are disposed of in accordance with the appropriate regulations.
- Do not use high pressure or steam jet cleaners. Do not use caustic cleaning agents.
- The lift's safety devices must be set by authorized service technicians.
- Do not replace or override the safety devices.

1.7 Safety Features

Dead Man's Type Control

The operator is required to hold the main switch in the engaged position to raise or lower the lift.

Pinch Point Protection

During lowering cycles the lift automatically stops shortly before reaching bottom position. To lower the lift completely, the "Lower" button must be released and pushed again. Lift travel to the lower limit stop is accompanied by an audible signal.

Cable Failure Protection

In case of cable failure the safety latches automatically engage the lock ladders. After cable failure the lift cannot be operated until the cable has been replaced.

Slack Cable Protection

If the lifting cables are slack, e.g. after contacting an obstacle, downward motion stops automatically.

Roll-off Protection

The ends of both runways are equipped with a roll-off protection means which safely prevents the vehicle from rolling off the lift.

Pressure Relief Valve

The hydraulic system is equipped with a pressure relief valve.

1.8 Safety Instructions for Handling Hydraulic Fluid

- Neutralize hydraulic fluid spills with binder.
- Remove contaminated clothing immediately.
- Inhalation: If symptoms persist, seek medical treatment.
- Skin contact: Wash skin immediately with soap and water. If skin irritation persists, seek immediate medical advice.
- Eye contact: Rinse thoroughly with water and seek medical advice.
- Ingestion: Do not induce vomiting. Seek immediate medical attention.

1.9 What to Do in the Event of Defects or Malfunctions

- In case of defects or malfunctions such as uncontrolled lift movement or deformation of the superstructure, support or lower the lift immediately.
- Turn off the main switch and secure it against unauthorized usage. Contact service.

1.10 What to Do in the Event of an Accident

- The injured person is to be removed from the danger area. Find out where dressing and bandages are kept. Seek first-aid.
- Provide first-aid (stop bleeding, immobilise injured limbs), report the accident and seal off the accident site.
- Immediately report any accident to your supervisor. Make sure a record is kept of every occasion first-aid is provided, e.g. in an accident book.
- Remain calm and answer any questions that may arise.

2 Description

2.1 General Information

The lift models of the CARLIFT II series are equipped with two runways supported by transverse beams serving as load carrying device. The drive system consists of one hydraulic cylinder with hydraulic power unit and a set of lifting cables. The lift is operated via a dead man's type control using pushbuttons.

2.2 Sample Nameplate



2.3 Specifications

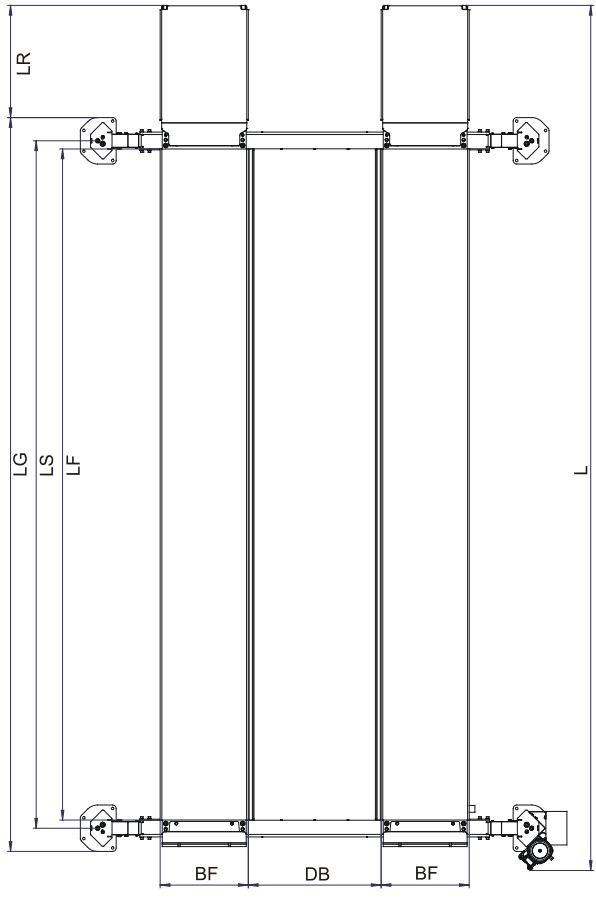
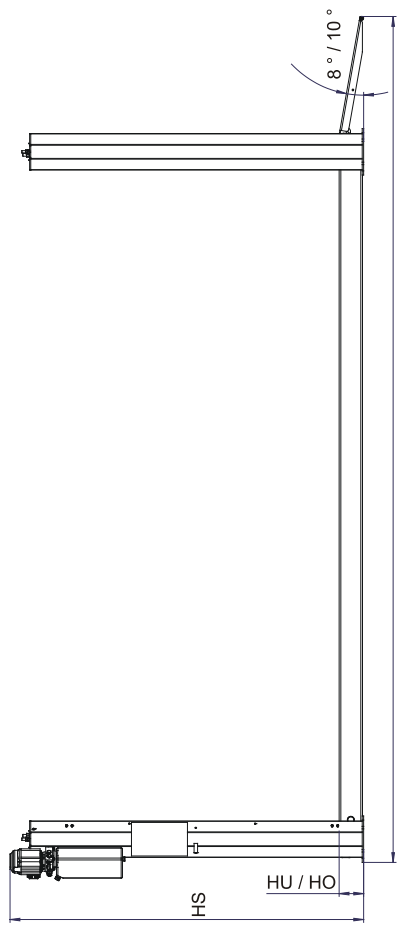
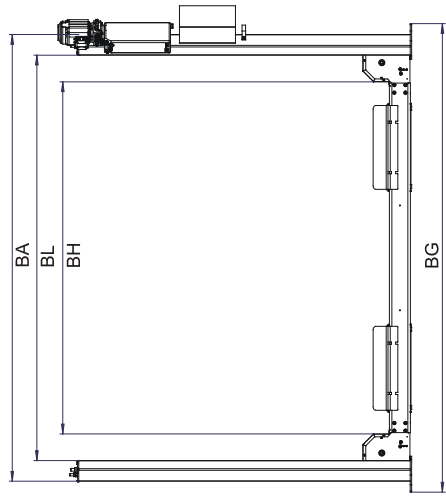

Fuse (time-delay)	16 A
Motor power	2,2 kW
Drive-on height	145 mm
Drive-on height with wheel alignment equipment and wheel-free jack	225 mm
Drive-on height with wheel alignment equipment	195 mm
Drive-on height with wheel-free jack	175 mm
Extension length Wheel-free jack max. (optional)	2000 mm
Extension length Wheel-free jack min. (optional)	1480 mm
Net weight	1500 kg
Runway width	630 mm
Runway length, standard	4400 mm
Runway length, optional	4800 mm
Total width	3320 mm
Length overall	5600 mm
Length overall (runway 4400 mm)	5775 mm
Lifting height wheel-free jack	440 mm
Lifting height max.	1965 mm
Lowering time, load-dependent approx.	30 s
Hydraulic fluid quantity	10 l
Inside runways max.	1020 mm
Inside runways min.	950 mm
Inside columns	2870 mm
Mains frequency	50 Hz
Mains voltage	400 V
Phases	3
Raising time, load-dependent approx.	30 s
Load capacity	4000 kg
Load capacity of wheel-free jack	3500 kg
Packaging (runway 4400 mm) (L x W x H)	4400 x 800 x 1200 mm

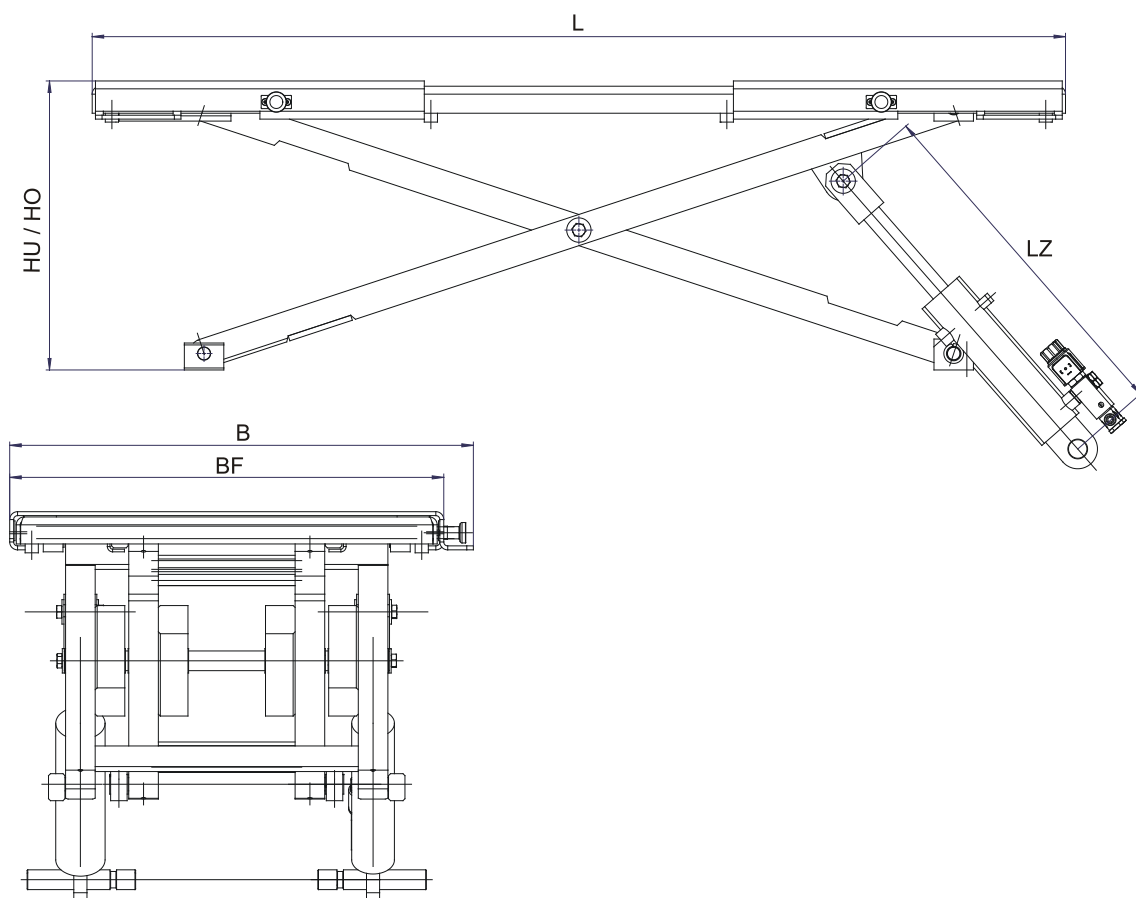

	RFH 2.5	RFH 3.5
Load capacity	2500 kg	3500 kg
Height above runway maximum HO	440 mm	
Height above runway minimum HU	65 mm	70 mm
Width overall B	705 mm	
Usable width of support plate BF	660 mm	
Length overall L	1480...1900 mm	1480...2000 mm
Cylinder length LZ	390...540 mm	

3 Transport and Storage

Check package to ensure it is complete, in accordance with the order confirmation. Report any transport damage to the carrier immediately.

During loading, unloading and transport always use suitable lifting equipment, material handling equipment (e.g. cranes, forklifts, etc.) and the right load handling attachments and slings. Always ensure that the parts to be transported are suspended or loaded properly so that they cannot fall, taking into account size, weight and the centre of gravity.

Store the packages in a covered area, protected from direct sunlight, at a low humidity and with temperatures between 0...40 °C (32...104 °F). Do not stack packages.

When unpacking, take care to avoid any possibility of injury or damage. Keep at a safe distance when opening the package strapping, do not allow any parts to fall out.

4 Installation and Initial Operation

Installation and initial operation of the equipment may be done only by authorized and trained service technicians provided by the manufacturer, licensed dealers or service partners.

5 Operation

5.1 Requirements on the Operator



All persons employed in the operation, maintenance, installation, removal and disposal of the plant must

- be at least 18 years old,
 - be trained and instructed in writing,
 - have read and understood this manual
 - be on record as having been instructed in safety guidelines.
-

5.2 Main Switch



The main switch is used as emergency switch. In case of emergency turn it to position 0.

- Main switch in position 0: Power supply is interrupted
- Main switch in position 1: Lift is ready for operation
- When in position 0, the main switch can be protected against tampering by means of a padlock.

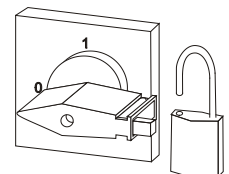

5.3 Controls

Overview

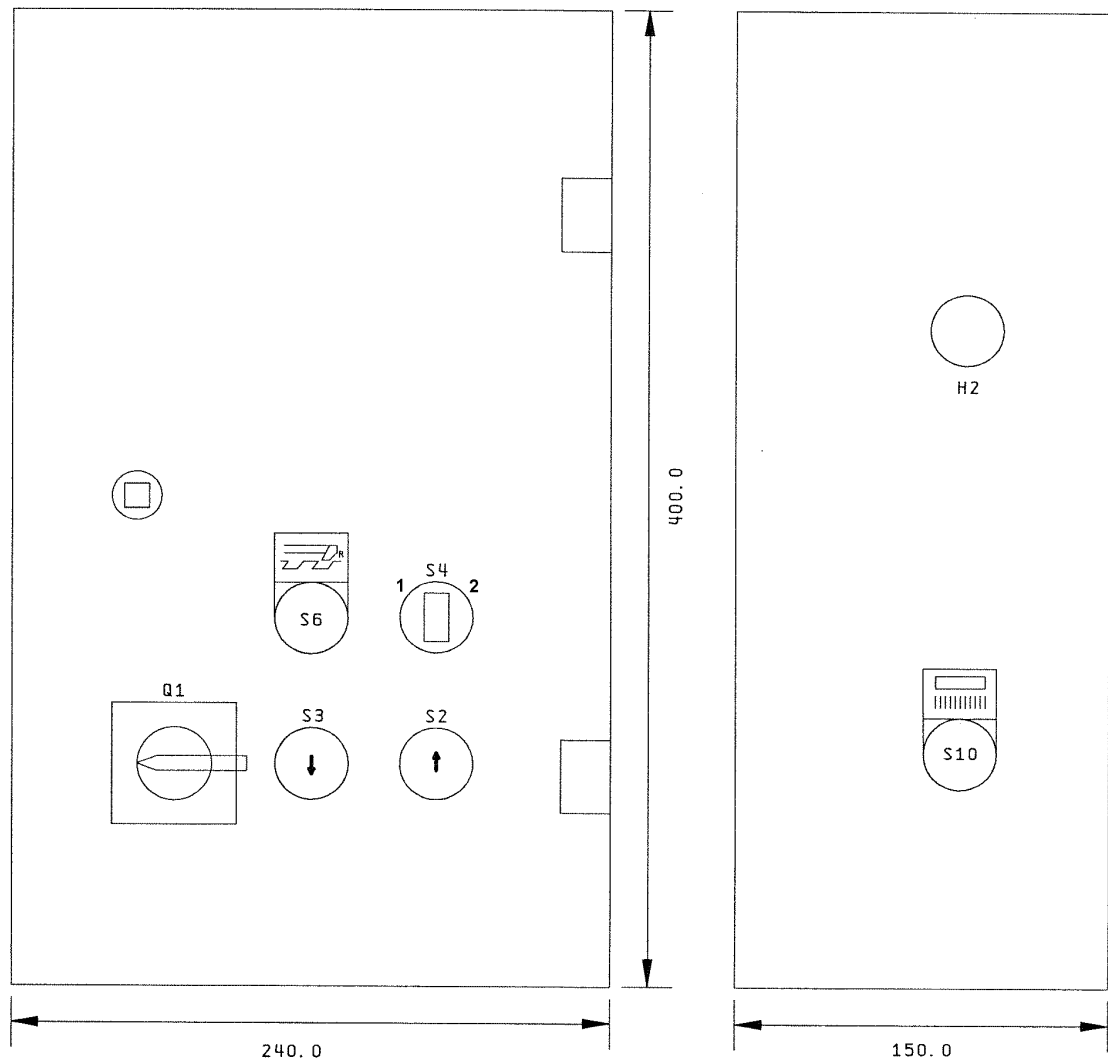

- S2** Raise
- S3** Lower
- S4** Change-over between
Lift (Pos. 1) / Wheel-Free Jack (Pos. 2)
- S6** Set on Locks

- H2** Pinch Point Protection (Audible Signal)
- S10** Lighting
- Q1** Main Switch

Raise

Press and hold this button to raise the lift / wheel-free jack. Lift stops once button is released or upward travel limit is reached.

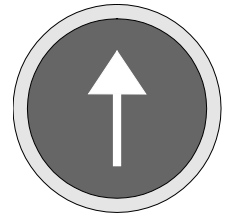
**Lower**

Press and hold this button to lower the lift / wheel-free jack. If equipped with mechanical lowering device, the lift raises shortly (for approx. 2 seconds) to disengage the latches from the lock ladder. Lift stops once button is released or downward travel limit is reached.

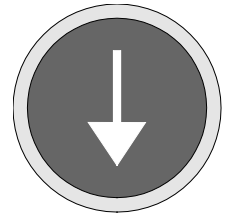
**Set on Locks**

Press this button to set the runways on the mechanical locks. In this way the lift can be firmly and exactly fixed for wheel alignment.

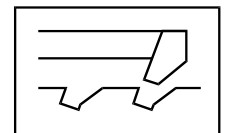
**Lighting**

Press this button to turn on and off the lamps between the runways.

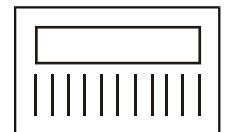

5.4 Using Support Blocks

- 1 The support blocks are approved for usage on lifts with a rated load capacity of 3,500 kgs.
- 2 Always use four original MAHA support blocks of identical size and shape.
- 3 Do not use support blocks with cracks, broken-off pieces or other damage.
- 4 Check that all support blocks and rubber pads are free of oil, grease, dirt or debris.
- 5 Place the support blocks under the vehicle manufacturer's recommended lift points.
- 6 Note correct positioning of the support blocks.
- 7 Raise the vehicle until the tyres clear the floor. Stop and recheck the lift supports for secure contact with the vehicle body.

The support block must be placed fully on the surface without extending beyond the edges.

A Extension

C Support block

B Support surface; available are:

- Granulate coating
- Granulate foil
- Rubber plate

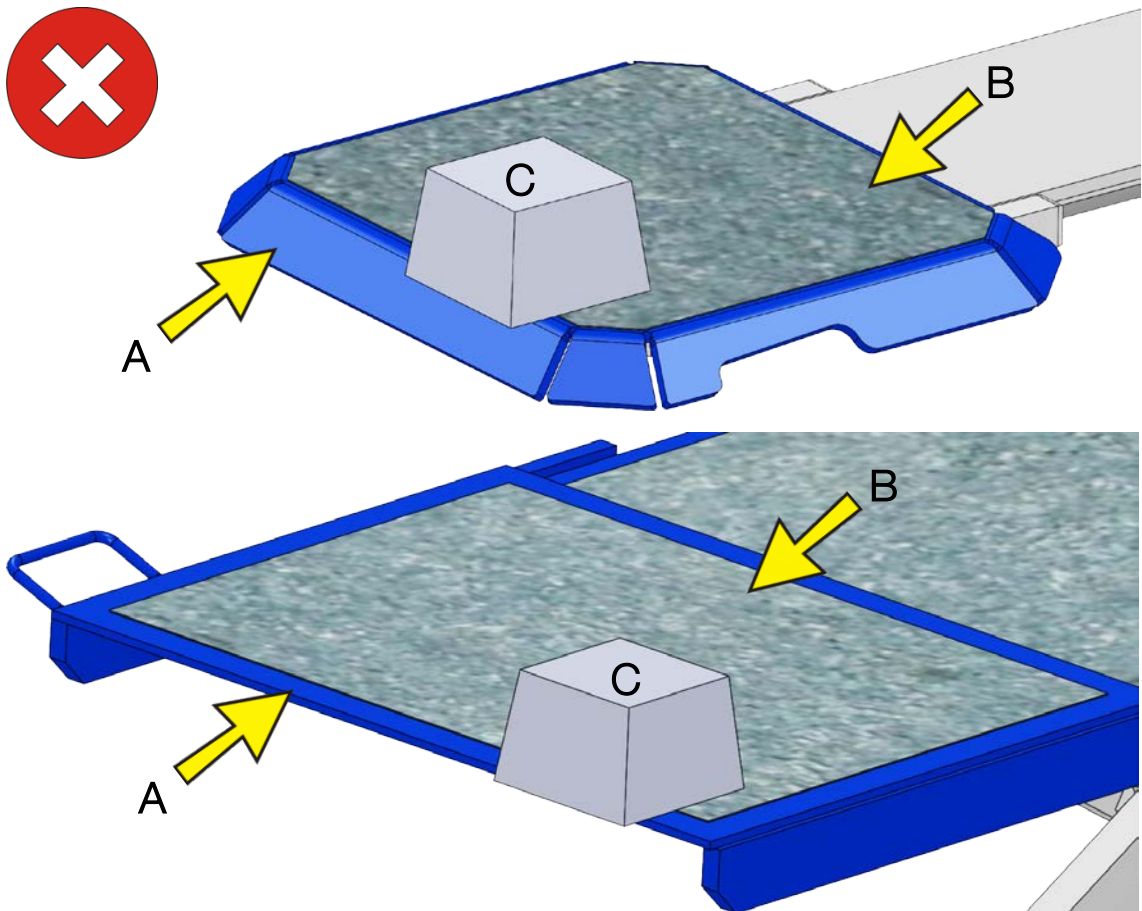

Diagonal positioning is permissible only with granulate coated surfaces (a). If knobby pads are used, these must mesh with the support blocks (b).

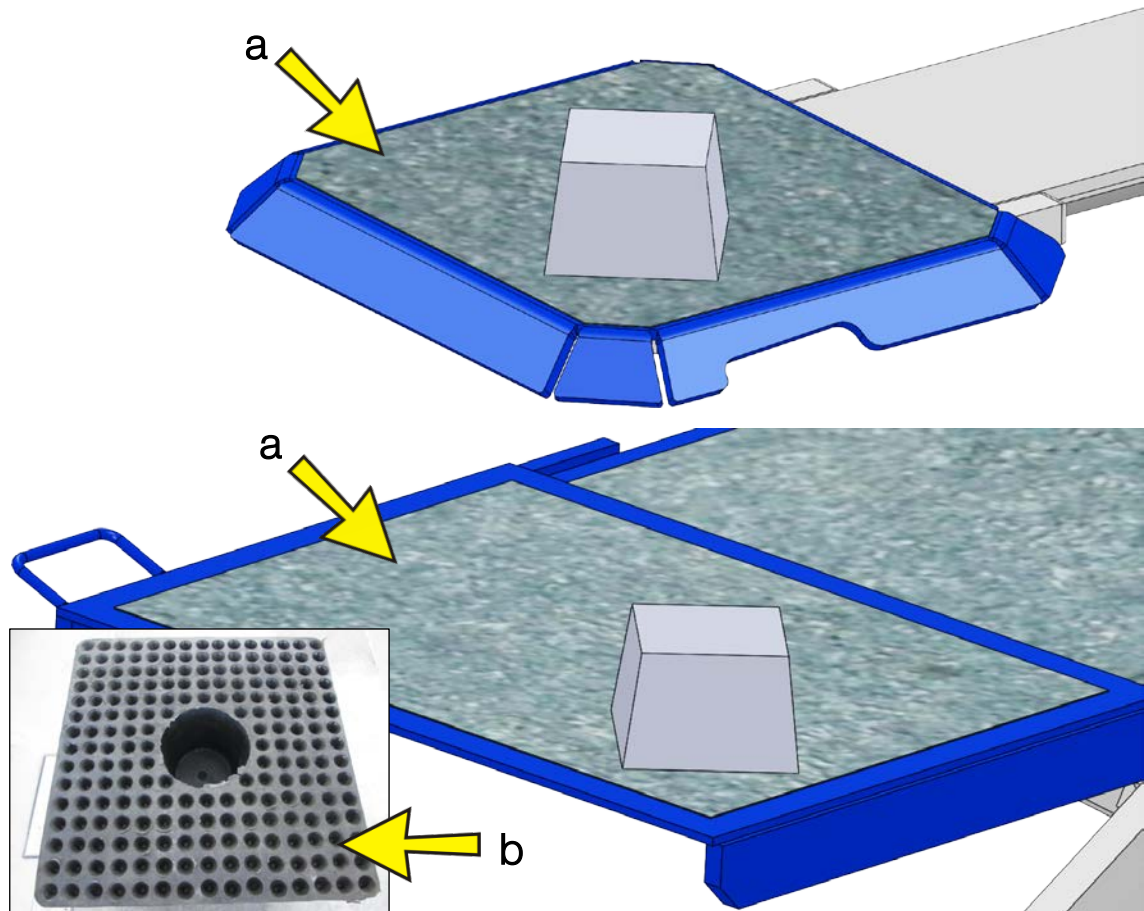

5.4.1 Stacking Two Blocks on Top of Each Other

Only the "DUO" hard rubber blocks (VZ 975074) and the ductile plastic blocks (VZ 970045) may be stacked on top of each other, but not more than two blocks per lifting point.

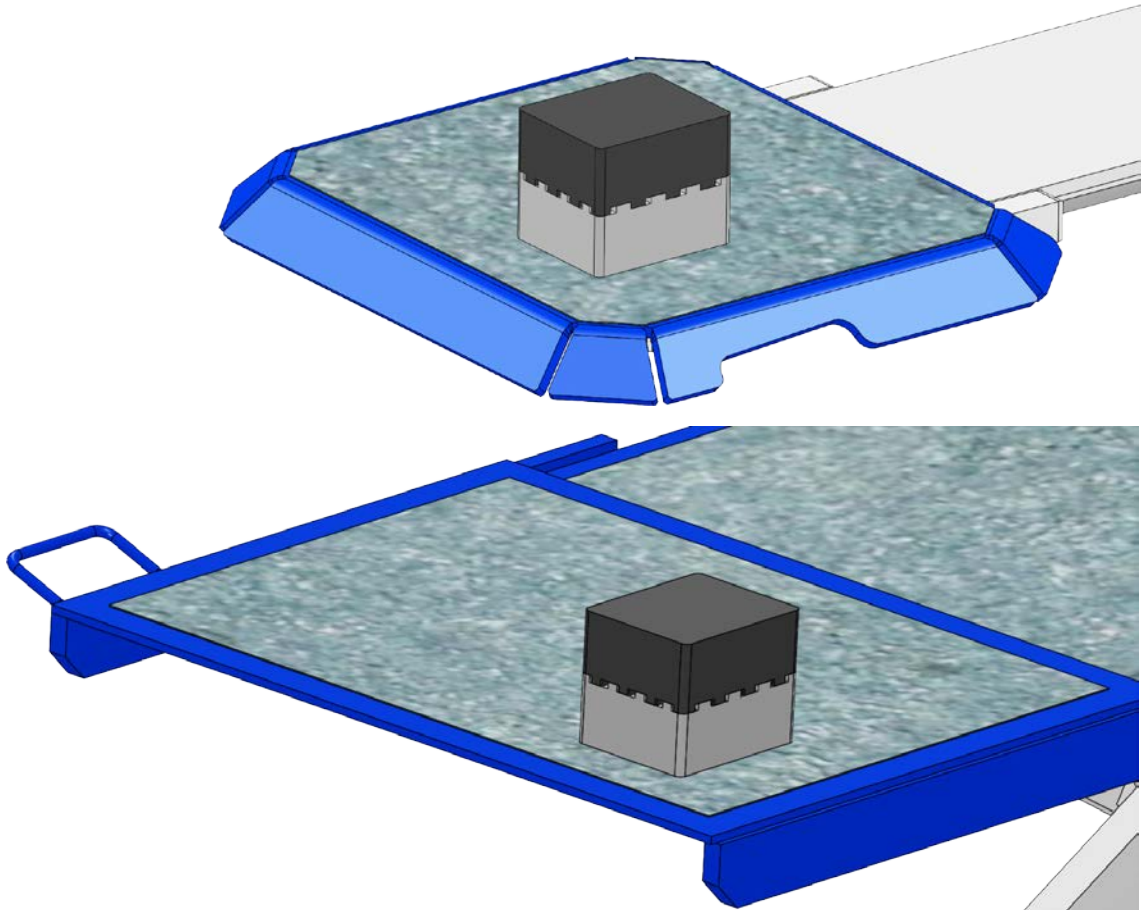

5.5 Raising

- Lift is in bottom position.
- 1 Center the vehicle on the lift.
- 2 Protect the vehicle against roll-off (parking brake, chocks).
- 3 Leave vehicle and stay clear of lift.
- 4 Turn main switch to position 1.
- Lift is ready for operation.
- 5 To raise the lift press RAISE button until the desired height is reached.
- Lift stops once button is released or upward travel limit is reached.
- 6 Set the lift on the mechanical locks as described in section "Wheel Alignment".

5.6 Lowering

- 1 Turn main switch to position 1.

- Lift is ready for operation.
- 2 To lower the lift press LOWER button until the desired height is reached.
- If equipped with mechanical lowering device, the lift raises shortly (for approx. 2 seconds) to disengage the latches from the lock ladder.



If the lift is in fully raised position, the lowering motion may be delayed by up to 3 seconds after the LOWER button has been pushed.

- Lift stops once button is released or the lower limit stop is reached. When fully lowering the lift, the lift stops shortly before bottom position.
- 3 To lower the lift completely, release the LOWER button and push it again.
- Lift motion to lower limit stop is accompanied by an audible signal (pinch point protection).
- 4 Turn main switch to position 0.
- 5 Release parking brake, remove chocks and drive the vehicle off the runways.

5.7 Wheel Alignment



Make sure to center the vehicle on the lift. Eccentric positioning may result in faulty measurement.

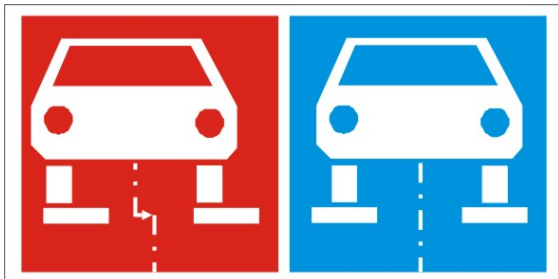

Setting the Lift on the Mechanical Locks

- Press and hold SET ON LOCKS button until all four latches are engaged on the lock ladder.
- Lift may lower approx. 10 cm when the runways are being set on the locks.

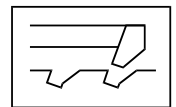

Disengaging the Locking Latches

- Press the LOWER button.
- Lift raises briefly (approx. 2 seconds) to disengage the latches from the lock ladder, and is ready again for regular operation.

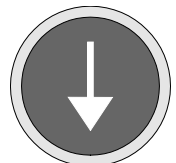

5.8 Lighting

- Press the LIGHTING button to turn on and off the lamps between the runways.

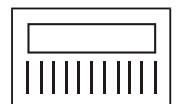

5.9 Wheel-Free Jack (Optional)

Raising

→ Vehicle must be centered over the wheel-free jack.

- 1 Lift the extensions using the handles and position them under the vehicle lift points.
- 2 If required, use additional spacer blocks under the vehicle.
- 3 Raise the vehicle briefly using button <WFJ UP> and check for secure contact of the extensions at the vehicle manufacturers' recommended lift points. Then raise the vehicle to the desired height.

→ Raising motion is stopped when button is released or upper limit stop is reached.

Lowering

- 1 Use button <WFJ DOWN> to lower the wheel-free jack.

→ Lowering motion is stopped when button is released or lower limit stop is reached. An audible warning signal sounds while the jack is lowering.

5.10 Manual Lowering



Authorized personnel only! Do not restart the lift before the error has been remedied.

5.10.1 Manual Lowering of Lift



- After cable failure, manual lowering is no longer possible. The lift cannot be operated until the cable has been replaced.
- Lifts with option "Set on Locks": Verify that the latches have not engaged the mechanical locks. The latches can be disengaged using a hand pump (optionally available). Otherwise contact your service representative.

Position of Valves

- Y2.1: Solenoid valve block inside the runway without cylinder
- Y1.0: Hydraulic power unit

Procedure for Lifts with Wheel-Free Jack

- 1 Remove the carriage covers from all four columns.
 - 2 Insert latch release plate (A) from below between lock ladder (B) and latch (C).
 - 3 Disable Y2.1 on the solenoid valve block.
 - 4 Push and hold Y1.0 on the hydraulic power unit.
- Caution! Lift begins to lower.
- 5 When lift is in bottom position, release Y1.0.
 - 6 After the error has been remedied, reset Y2.1 into operating condition.
 - 7 Reattach the carriage covers.

Procedure for Lifts without Wheel-Free Jack

- 1 Remove the carriage covers from all four covers.
- 2 Insert latch release plate (A) from below between lock ladder (B) and latch (C).
- 3 Push and hold Y1.0 on the hydraulic power unit.
→ Caution! Lift begins to lower.
- 4 When lift is in bottom position, release Y1.0.
- 5 Reattach the carriage covers.

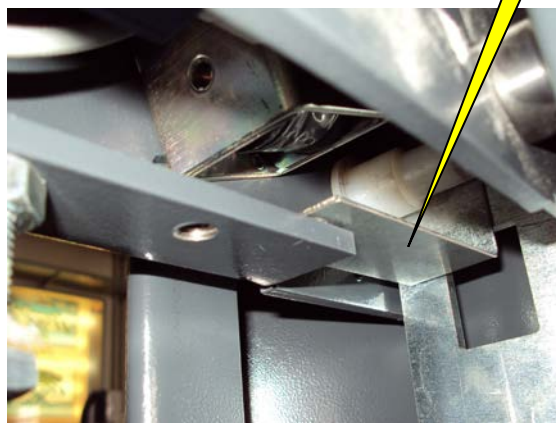
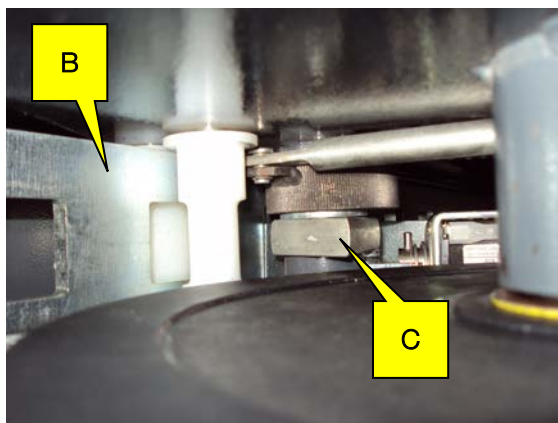
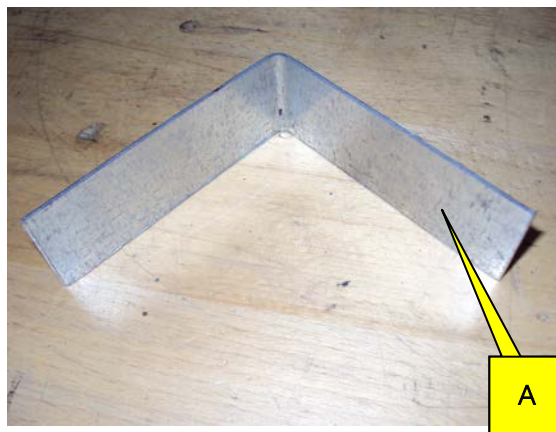
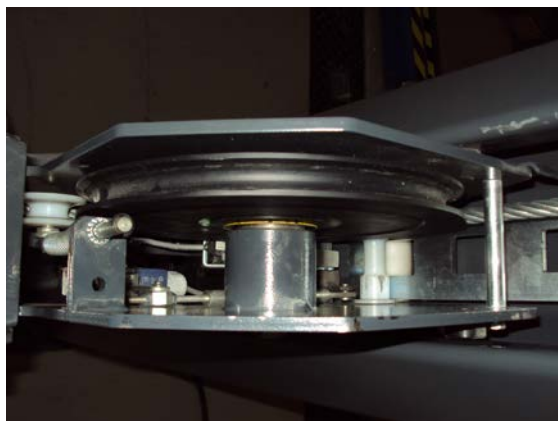
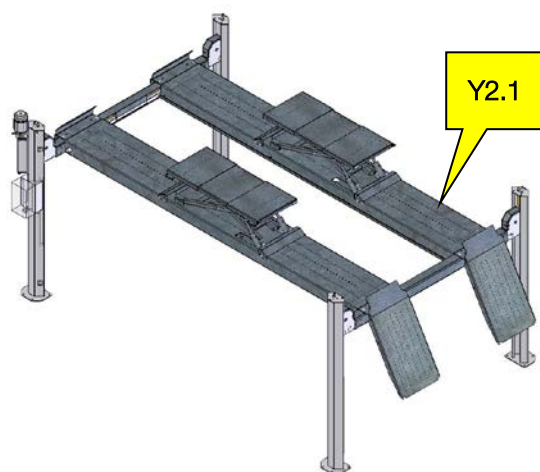

5.10.2 Manual Lowering of Wheel-Free Jack

Position of Valves

- Y2.2: Solenoid valve block inside runway without cylinder
- Y8.1, Y8.2, Y8.3, Y8.4: Cylinder of wheel-free jack
- Y1.0: Hydraulic power unit

Procedure

- 1 Disable Y8.1, Y8.2, Y8.3 and Y8.4.
- 2 Disable Y2.2.
- 3 Push and hold Y1.0, until the wheel-free jack is in bottom position.
- 4 After the error has been remedied, reset the valves into operating condition.

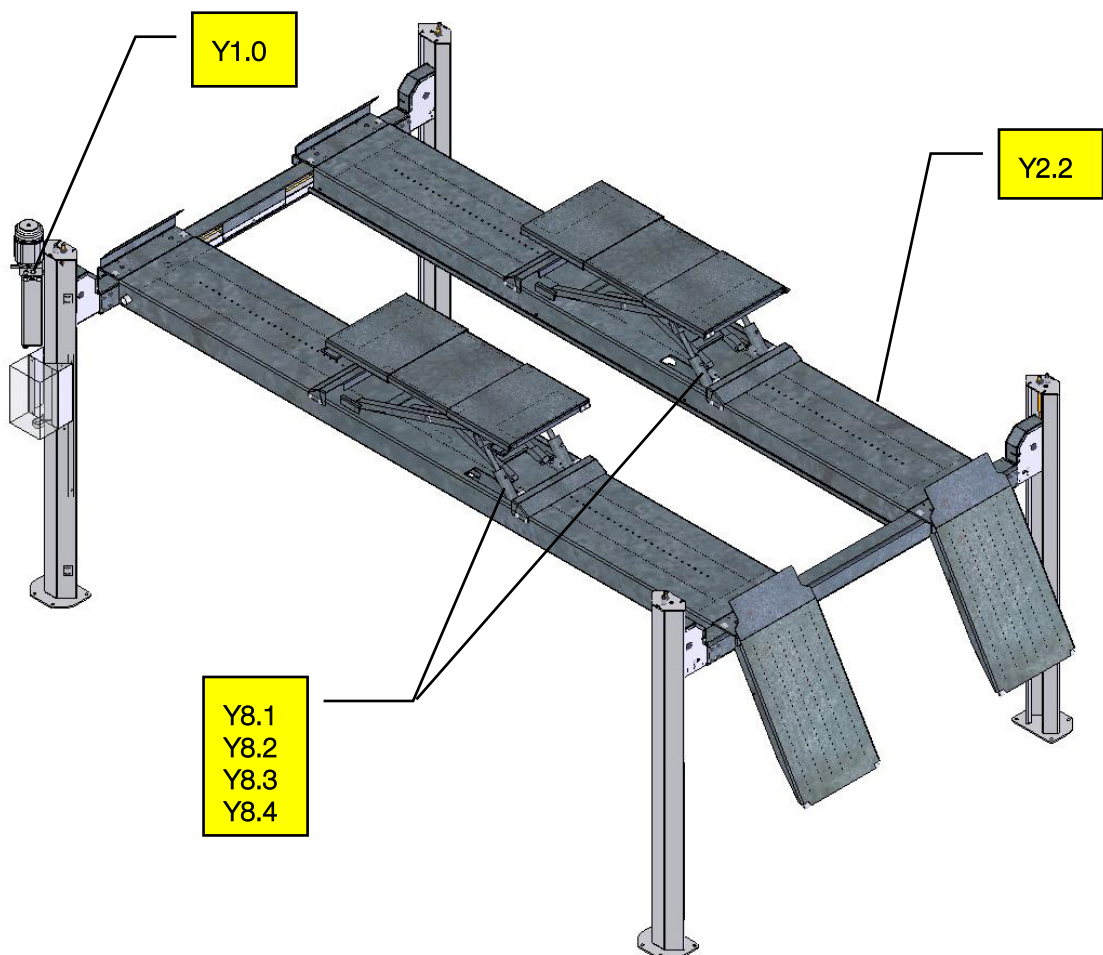

6 Maintenance



Danger! Electric shock hazard!

Before doing any maintenance work, turn off the main switch and protect it against tampering.

6.1 Maintenance Schedule

Interval	Maintenance items	Procedure
3 months	Hydraulic system	Check fluid level, top up if necessary.
		Check hydraulic system for leakage.
		Check power unit for unusual noise during operation. Check fastening screws for tight fit.
	Slider tracks and sliding surfaces of extensions	Grease slightly.
	Wire ropes	Check for wear/corrosion, replace if necessary.
6 months	Hydraulic fluid	Check for soiling/aging, replace if necessary.
12 months	General inspection	Check all components for damage.
6 years	Pressure hoses	Replace pressure hoses.

6.2 Annual Inspection



- The maintenance interval prescribed by the manufacturer is **12 (twelve) months**. This maintenance interval refers to normal workshop usage. If the equipment is used more frequently or under severe operating conditions (e.g. outdoors), the interval must be reduced accordingly.



- Maintenance work shall be done only by authorized and trained service technicians provided by the manufacturer, licensed dealers or service partners.
- In case of non-compliance the manufacturer's warranty becomes void.

6.3 Checking the Fluid Level



- Replace the hydraulic fluid periodically, depending on aging, soiling and water absorption.
- When topping up, use fluid with the same specification only.
- If the lift is operated permanently at an ambient temperature of $< 15\text{ }^{\circ}\text{C}$, use hydraulic fluid with a lower viscosity.
- The pressure hoses should be replaced as required, but after six years at the latest.

- Periodically check the fluid level. The level must be between the **max**- and **min**-marks.
- To check the fluid level, fully lower the lift.
- Open the filler neck and top up the reservoir. Reservoir capacity is approx. 9 l.
- Visually check all hydraulic lines for leakage.



6.4 Greasing the Slide Tracks

Periodically clean the slide tracks on the runways and on the bottom side of the wheel-free jack. Grease slightly.



6.5 Inspecting the Wire Ropes

Inspection for Safe Operating Condition

All wire ropes, rope ends and pulleys must be checked annually for their safe operating condition by an authorized service technician. If visible damage is found, the inspection interval must be appropriately shortened.

Inspection for Uniform Rope Tension

All ropes must be checked periodically for uniform tension by an authorized service technician. Incorrect setting of the rope tension results in unequal load distribution and premature wear of the cylinder piston rod.

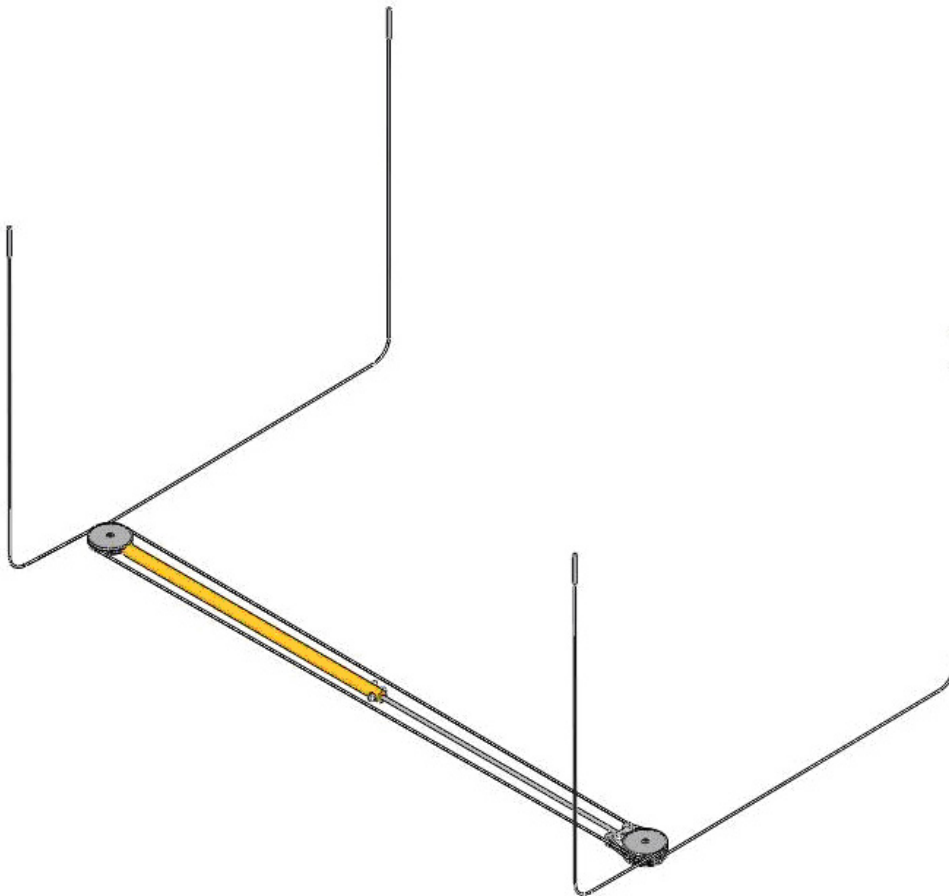

6.6 Care Instructions

- Periodically clean the equipment and treat it with a care product.
- Repair damage to the paintwork immediately to prevent corrosion.
- Usage of caustic cleaning agents or high pressure and steam jet cleaners may lead to equipment damage.



Regular care and maintenance is the key condition for functionality and long life expectancy of the equipment!

6.7 Troubleshooting

Trouble	Diagnosis	Remedy
Lift does not run.	Main switch off.	Turn on main switch.
	Mains fuse defective.	Replace mains fuse.
	Fuse F1 in control unit defective.	Replace fuse.
Lighting cannot be switched on.	Fuse F2 in control unit defective.	Replace fuse.
Lift does not raise.	Reverse motor rotation.	Interchange two phases at main switch.
	Low fluid level.	Top up reservoir.
	Manual lowering screw at solenoid valve Y2 open.	Close manual lowering screw.
	Hydraulic system leaking.	Remove leakage.
Lift shows uncontrolled movements.	Air in hydraulic system.	Bleed hydraulic system.

6.8 Spare Parts

To ensure safe and reliable operation, only use original spare parts supplied by the equipment manufacturer.

7 Service Lifetime

In its standard version, this product is designed for 22,000 load cycles based on EN 1493. The maximum period of normal use in relation to the possible product life expectancy shall be evaluated and scheduled by a qualified person during the annual safety inspection.

8 Dismantling

Decommissioning and dismantling of the equipment may be done only by specially authorized and trained personnel provided by the manufacturer, licensed dealers or service partners.

9 Disposal

Pay attention to the product and safety data sheets of the lubricant used. Avoid damage to the environment. Should a disposal of the device be necessary it must be done in adherence with locally applicable legal regulations regarding environmental protection. Remove all materials properly sorted out and bring them to a suitable waste disposal service. Collect operating materials such as grease, oils, coolant, solvent-based cleaning fluids etc. in suitable containers and dispose of in an environmentally protective manner.

10 Contents of the Declaration of Conformity

Model:	CARLIFT II 4.0; CM II 4.40
Designation:	Four Post Lift; Rated Load Capacity 4000 kg Option: Wheel-Free Jack; Rated Load Capacity 2500/3500 kg
EC Directives:	2006/42/EC; 2014/30/EU
EN Standards:	EN 1493; EN 60204-1

11 Company Information

© MAHA Maschinenbau Haldenwang GmbH & Co. KG

Legal notice based on ISO 16016:

The reproduction, distribution and utilization of this document as well as the communication of its contents to others without explicit authorization is prohibited. Offenders will be held liable for the payment of damages. All rights reserved in the event of the grant of a patent, utility model or design.

The contents of this edition have been checked with great care. However, errors cannot be fully excluded. Subject to technical change without notice.

Document

Document No.: BA363101-en
Approval Date: 2016-07-28

Manufacturer

MAHA Maschinenbau Haldenwang GmbH & Co. KG
Hoyen 20
87490 Haldenwang
Germany

Phone: +49 8374 585 0
Fax: +49 8374 585 590
Mail: maha@maha.de
Web: <http://www.maha.de>

Service

MAHA Service Center
AutomoTec GmbH
Maybachstraße 8
87437 Kempten
Germany

Phone: +49 8374 585 100
Fax: +49 8374 585 491
Mail: service@automo-tec.com
Web: www.automo-tec.com