



ZS DUETT

Two Post Inground Lifts

Original Operating Instructions

BA320301-en

ZS DUETT 3.5 FT
ZS DUETT 3.5 GS
ZS DUETT 4.5 GS
ZS DUETT 5.0 GS

© MAHA SE & Co. KG

The reproduction, distribution and utilisation of this document as well as the communication of its contents to others without explicit authorisation is prohibited. Offenders will be held liable for the payment of damages. All rights reserved in the event of the grant of a patent, utility model or design.

The contents have been checked with great care; however, errors cannot be fully excluded. Illustrations are examples and may differ from the original product. Subject to technical change without notice.

Manufacturer

MAHA SE & Co. KG
Hoyen 20 | 87490 Haldenwang | Germany

☎ +49 8374 585-0

✉ maha@maha.de

🌐 www.maha.de

Service

MAHA SERVICE CENTER
Maybachstraße 8 | 87437 Kempten | Germany

☎ +49 8374 585-100

✉ service@maha.de

🌐 www.mahaservicecenter.de

Dear Customer,

MAHA is one of the world's leading manufacturers of testing and lifting technology and places particular emphasis on quality and performance. The company's concept includes the development, manufacture and sale of products for use in automotive workshops, by vehicle manufacturers and testing organisations.

MAHA's claim is to also be a leader in the areas of reliability, safety and sustainability – this can be seen in many details that have been developed with these aspects in mind.

We are convinced that you will be more than satisfied with the quality and performance of our products for many years. With the purchase of our products you will also receive professional assistance in case of need for service and repair.

Please remember to keep these operating instructions in a safe place. Accurately following their contents will significantly extend the life of your product and also increase its resale value. If you sell your product, please also pass on the operating instructions.

MAHA is constantly working on the further development of all products and therefore reserves the right to make changes, e.g. in shape and appearance, without prior notice.

Extensive accessories, useful assembly material and auxiliary materials are available for our products. For further information, please ask your dealer or your MAHA contact person at any time.

Thank you for choosing a MAHA product!

Contents

1	General Safety Instructions	5
1.1	Introduction	5
1.2	Symbols and Signal Words	5
1.2.1	Personal Injury	5
1.2.2	Property Damage	5
1.3	What to Do in the Event of Defects or Malfunctions	6
1.4	What to Do in the Event of an Accident	6
1.5	Requirements for the Operating Personnel.....	6
1.6	Requirements on Service Personnel.....	6
1.7	Intended Use	7
1.8	Safety Instructions for Handling Hydraulic Fluid	7
2	Description	8
2.1	Applicable Standards and Directives.....	8
2.2	Service Life.....	8
2.3	General Machine Description.....	8
2.3.1	Design and Basic Functions	8
2.3.2	Control Description	9
2.3.3	Safety Devices	10
2.3.4	Overall View with Components	11
2.4	Technical Data	14
2.4.1	Danger Zone	14
2.4.2	Technical Data.....	15
2.4.3	Set-up Diagrams.....	16
3	Transport, Handling and Storage	19
3.1	Safety Instructions.....	19
3.2	Transport, Handling and Storage.....	19
4	Operation	20
4.1	Safety Instructions.....	20
4.2	Preparations.....	21
4.2.1	Initial Position/Ready for Operation	21
4.2.2	Positioning of the Vehicle	21
4.2.3	Positioning of the Supports	22
4.3	Raising and Lowering Cycles	24
4.3.1	Control Elements.....	24
4.3.2	Approaching the Vehicle and Checking for Safe Pick-up	26
4.3.3	Lowering Process and CE Stop	26
4.4	Driving off the Lift and Changeover	27
4.5	Emergency Lowering	28
4.5.1	Electric Emergency Lowering	28
4.5.2	Mechanical Emergency Lowering	29
4.6	Optional Equipment	30
4.6.1	Hinged Cover Frame	30
4.6.2	Installation Frame for Flat Head Lifts	32
4.6.3	Wheel Engaging Support.....	32

4.6.4	Special Prism Support – Plug-in System	34
4.6.5	Additional Jointed Arm	34
4.6.6	Support Disc System (ATS)	37
4.6.7	Ceiling Light Barrier	44
4.6.8	Cable Remote Control	44
5	Troubleshooting	45
5.1	Safety Instructions	45
5.2	LED Signal Codes	46
5.3	Troubleshooting Table	48
6	Inspection	49
6.1	Safety Instructions	49
6.2	Daily Inspection before Starting Work	50
6.2.1	Cables and Actuators	50
6.2.2	Emergency Stop	50
6.2.3	Limitation of the Support Arm Pull-outs	50
6.2.4	Limitation of the Support Arm Lock	50
6.2.5	Load Supports	51
6.2.6	Piston Rod and Toothed Rack	51
6.2.7	Pull-out of the Flat Head Support	51
6.2.8	Fastening Screws	52
6.3	Six-Monthly Inspection	52
6.3.1	Oil Level and Hydraulic Oil	52
6.3.2	Tightness of the Hydraulic System	53
6.4	Yearly Inspection	53
6.4.1	Welded Joints	53
6.4.2	Tightening Torques	53
6.4.3	CE Stop	54
6.4.4	Hydraulic Hose Line	54
7	Servicing	55
7.1	Safety Instructions	55
7.2	Lubrication	56
7.2.1	Piston Rod	56
7.2.2	Toothed Rack	56
7.2.3	Support Arm Pull-outs	56
7.2.4	Support Arm Lock	56
7.2.5	Flat Head Support Pull-outs	56
7.3	Hydraulic Hose Lines	57
7.4	Support Structure Screws	57
7.5	Bleeding the Hydraulic System	57
8	Care Instructions	60
9	Repairs	60
10	Decommissioning, Dismantling and Disposal	60
11	Declaration of Conformity	60

1 General Safety Instructions

1.1 Introduction

- These operating instructions must be read carefully and understood before work commences.
- Please observe the specific safety information provided for the respective sections of the operating instructions.
- Adhering to the procedures, sequences and corresponding safety instructions is essential.
- A printed copy of the operating instructions must always be kept by the lift.
- The relevant regulations on accident prevention and health protection must be observed.

1.2 Symbols and Signal Words

1.2.1 Personal Injury



DANGER

indicates an immediate hazard which, if not avoided, will result in death or severe personal injury.



WARNING

indicates a potential hazard which, if not avoided, could result in death or severe personal injury.



CAUTION

indicates a potential hazard which, if not avoided, could result in moderate or minor personal injury.

1.2.2 Property Damage

NOTICE

indicates a potentially harmful situation which, if not avoided, could result in damage to the equipment or surrounding objects.

1.3 What to Do in the Event of Defects or Malfunctions

- If any irregularities occur, immediately lower or support the lift to the basic position.
- Turn off the main switch and secure against unauthorised use.
- Contact service team.

1.4 What to Do in the Event of an Accident

- Notify first aiders, the ambulance service and/or immediate care doctor:
 - Where did the accident happen (address, workshop ...)?
 - What happened?
 - How many are injured?
 - What injuries have occurred?
 - Who is reporting the accident?
- Keep calm and answer questions.

1.5 Requirements for the Operating Personnel

All persons involved in the operation of the equipment must

- be 18 years of age or older,
- have the mental and physical capacity for their role,
- be demonstrably trained and instructed in writing in the operation of the system,
- have read and understood the operating instructions, in particular the instructions on what to do in the event of a fault,
- demonstrate experience and knowledge in handling the equipment and the hazards it presents,
- be instructed in safety guidelines on record.

1.6 Requirements on Service Personnel

Persons who are entrusted with the assembly, maintenance and/or disassembly of the equipment must in addition:

- be demonstrably trained and instructed in the required work,
- can provide evidence of appropriate qualification for work on the electrical equipment of the plant (e.g. as a qualified electrician),
- be able to demonstrate expertise for vehicle lifts. This includes sufficient knowledge in the field of lifts and the relevant statutory occupational health and safety regulations, accident prevention regulations and generally accepted rules of technology to be able to assess the safe working condition of the lift to be tested. Qualified persons shall not only consider the current condition of the lift during the inspection. They must also be able to estimate how the lift and its structural parts will behave under operational con-

ditions in the sequence and how wear, aging and the like will affect the safety of the lift.

1.7 Intended Use

- The lift is intended exclusively for the safe lifting and lowering of passenger cars and commercial vehicles up to the total weight according to the type plate within the scope of service and repair work.
- In compliance with the load distribution regulations of DIN EN 1493, the permitted load capacity on the identification plate must not be exceeded.
- Only vehicles which are suitable for the lifting equipment due to their shape and the positioning of their lifting points may be lifted.
- The lift may not be modified without express written permission from the manufacturer. Non-compliance invalidates the declaration of conformity.

1.8 Safety Instructions for Handling Hydraulic Fluid

- Wear personal protective equipment (PPE).
- Neutralize spilled hydraulic oil with binding agent.
- Immediately remove soiled, saturated clothing.
- After inhalation: Medical treatment in case of complaints.
- After skin contact: Wash skin immediately with soap and water. Consult a physician if skin irritation persists.
- After eye contact: Rinse thoroughly with plenty of water, consult physician.
- After ingestion: Do not induce vomiting. Call a doctor immediately.

2 Description

2.1 Applicable Standards and Directives

The lift has been designed in accordance with the applicable standards and regulations. The most important of these are:

- 2006/42/EC Machinery Directive
- 2014/30/EU Electromagnetic Compatibility Directive
- 2014/35/EU Low Voltage Directive
- DIN EN 1493:2011 Vehicle Lifts
- DIN EN 60204-1-100:2019 Electrical equipment of machines - General requirements
- DIN EN ISO 13849-1:2016 Safety-related parts of control systems - General principles for design

2.2 Service Life

The lift is designed and tested according to DIN EN 1493. The assumptions therein are valid for 22,000 full load cycles. After reaching this number of cycles, or after a maximum of 10 years, the lift must be replaced by a new product or be given a general overhaul.

A general overhaul should only be carried out by the manufacturer or persons authorized by them. Load-bearing structures must be inspected and, if necessary, other parts must be replaced according to the manufacturer's specifications.

2.3 General Machine Description

2.3.1 Design and Basic Functions

The lift consists of lifting units with flat head supports or swing arm supports. The lifting units are hydraulically operated and mechanically interconnected. The lifting units are mounted in concreted installation boxes or installation frames. The hydraulic unit is suspended in the installation box or in the installation frame, or stands on the floor away from the lift.

The lift is operated via the control element of the control box. Lifting and lowering of the lift is performed via pushbuttons. The cable routing from the control box to the lift is underfloor.

Lifting unit

The lifting units consist of a left and a right version. These are of mirror-image and redundant design and are connected via a mechanical synchronous connection. The lifting units are welded together from the two components cylinder head and tank tube. Depending on the version, the cylinder head is screwed to the installation box or the installation frame or clamped via clamping elements. The cylinder head thus transfers the load from the vehicle

to the foundation. The piston rod is guided in the cylinder head. An anti-rotation device mounted in the piston rod and tank tube prevents the piston rod from rotating. A mechanical end stop limits the maximum stroke of the lift.

The cylinder head also guides the toothed rack. The toothed rack is connected to the support and to the synchronisation connection, thus establishing synchronisation between the two lifting units.

The toothed rack also actuates an electric limit switch. This limit switch triggers the CE stop during the lowering process.

Supports

Flat head support:

Flat head supports consist of flat heads and pull-outs. The pull-outs are available in various designs. The flat head supports are bolted to the piston rod and the rack. The pull-outs are suspended on the flat head, guided laterally and secured against tilting. Two grooved pins are driven into the flat head, which engage in the holes of the pull-outs. The pull-outs can thus be pinned at fixed intervals along the flat head, if required. The pull-outs are either equipped with nubbed rubber plates or have a granular coating.

Swing arm support:

Swing arm supports consist of swing arm carrier and telescopic support arms. When the lift is lowered, the support arms are rotatably mounted in the swing arm carriers via swing arm pins. The rotation of the support arms is automatically blocked by the support arm lock when raised. The swing arm supports are bolted to the piston rod and the rack.

Support plates are screwed into the support arms, these are adjustable in height via the thread.

Hydraulic power unit

The hydraulic power unit consists of an oil reservoir and a cover. The motor-pump unit and the hydraulic block are mounted on the cover. The motor-pump unit is connected to the hydraulic block by means of a hose or pipe. The hydraulic block contains all valves and connections relevant for the function of the lift. The cover is bolted to the oil reservoir, the oil reservoir stores the hydraulic oil.

2.3.2 Control Description

The core of the control system is a control board that performs, monitors and controls all electrical functions necessary for safe operation of the system. This control board is mounted on the inside of the control cabinet.

The lift is controlled with pushbuttons on the operating element. These have arrows, which show the direction of movement. Above the control buttons there are fault indicators which light up yellow or red periodically or permanently in the event of a fault. The main switch on the control box is also an emergency stop switch.

Optionally, the lift can be equipped with a ceiling light barrier, a control panel, or a cable remote control. An emergency stop switch is also attached to the cable remote control.

The lift is equipped with the small control element as standard. As soon as the

lift is equipped with additional options, it is equipped with the large control element.

2.3.3 Safety Devices

- **Synchronisation connection**
The lifting units are connected to a synchronous shaft via the toothed racks. This limits the height offset between the two piston rods to a maximum of 50 mm.
- **Dead man control**
Each pushbutton is only active as long as it is pressed (dead man control). When the corresponding buttons are released, the raising and lowering movements are immediately interrupted.
- **Emergency stop**
The main switch on the switch box of the lift is also an emergency stop switch. An emergency stop switch is located on the optional cable remote control.
- **Pressure relief valve**
The hydraulic power unit has a pressure relief valve. The pressure relief valve is factory set and limits the hydraulic pressure within the lift.
- **Seat valves**
All valves of the lift are designed as seat valves and are closed in the rest position. In the event of a leak, controlled lowering is still possible; in the event of a power failure, the lift will not lower itself.
- **Pinch point protection**
The lift has an automatic stop at a distance of at least 120 mm between the support and the workshop floor (pinch point protection). Pressing the "DOWN" button again lowers the lift with an acoustic signal.
- **Support arm lock**
The support arm lock automatically locks in the raised state, so that it is not possible to change the position of the support arms when loaded.
- **Ceiling light barrier**
Optionally, the lift can be equipped with a ceiling light barrier. The overhead light barrier prevents a lifting movement beyond a defined range.

2.3.4 Overall View with Components

Lifting unit

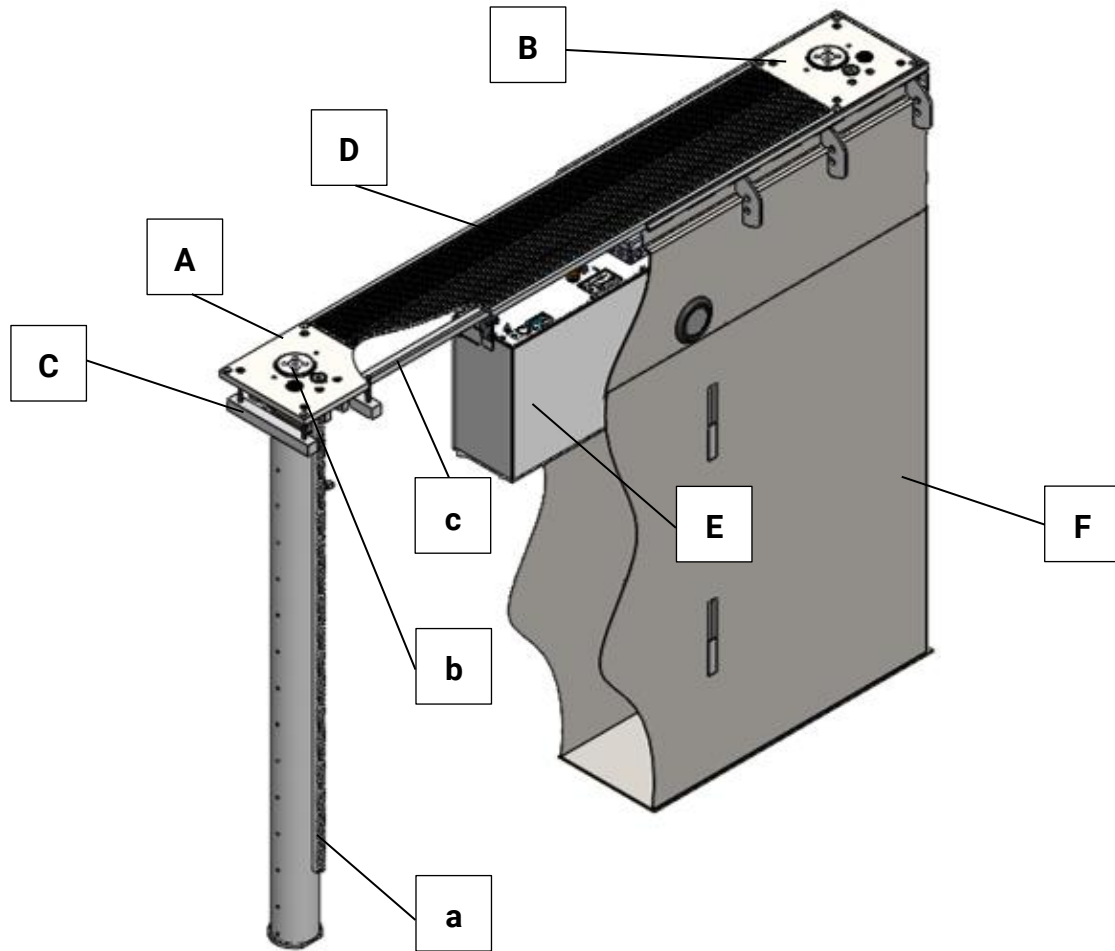

- | | | | |
|----------|--|----------|----------------------------|
| A | Lifting unit left | a | Toothed rack |
| B | Lifting unit right | b | Piston rod |
| C | Clamping element | c | Synchronisation connection |
| D | Cover | | |
| E | Hydraulic power unit | | |
| F | Installation box (incomplete illustration) | | |

Flat head support

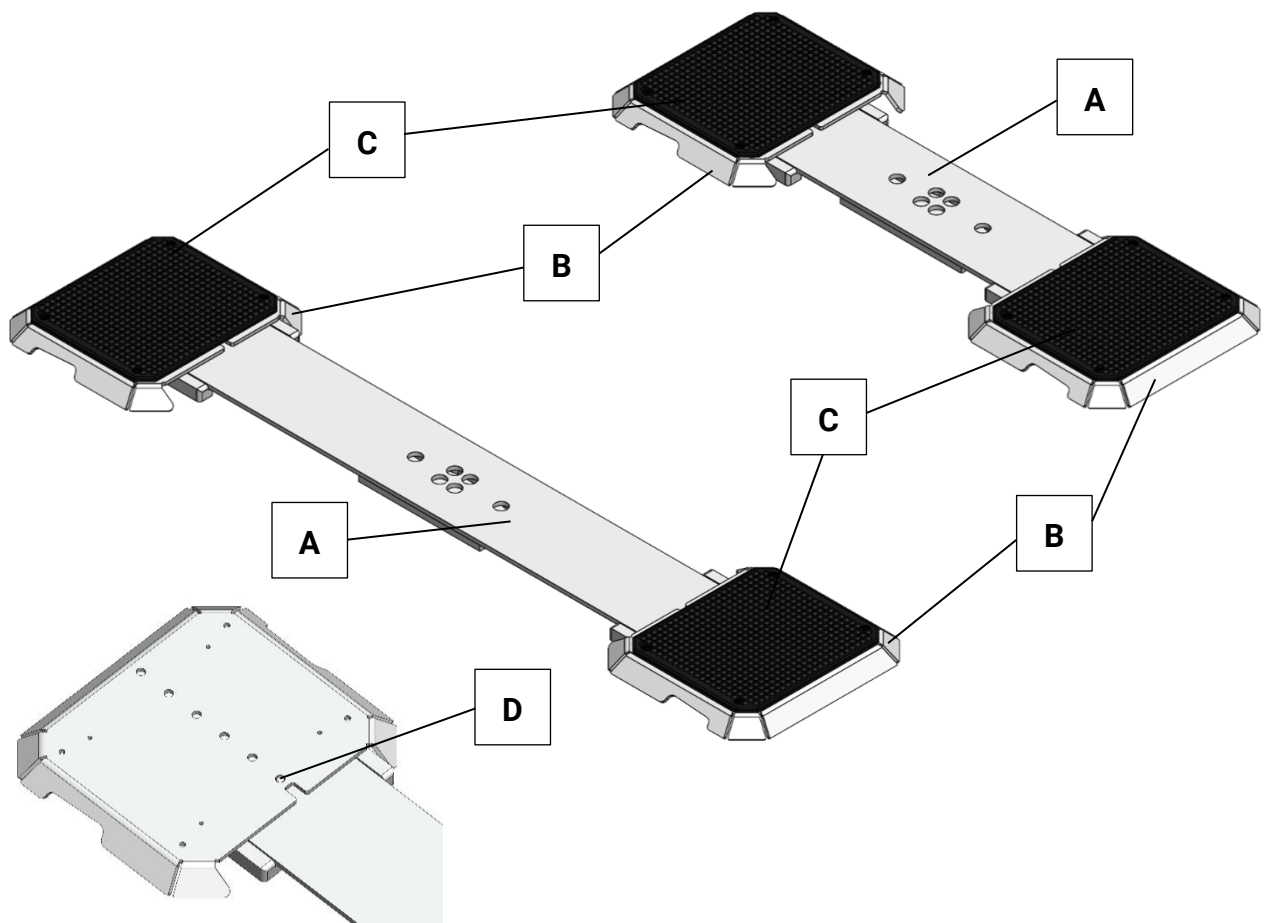

Illustration without rubber pad

A Flat head

B Pull-out

C Rubber pad

D Grooved pin

Swing arm support

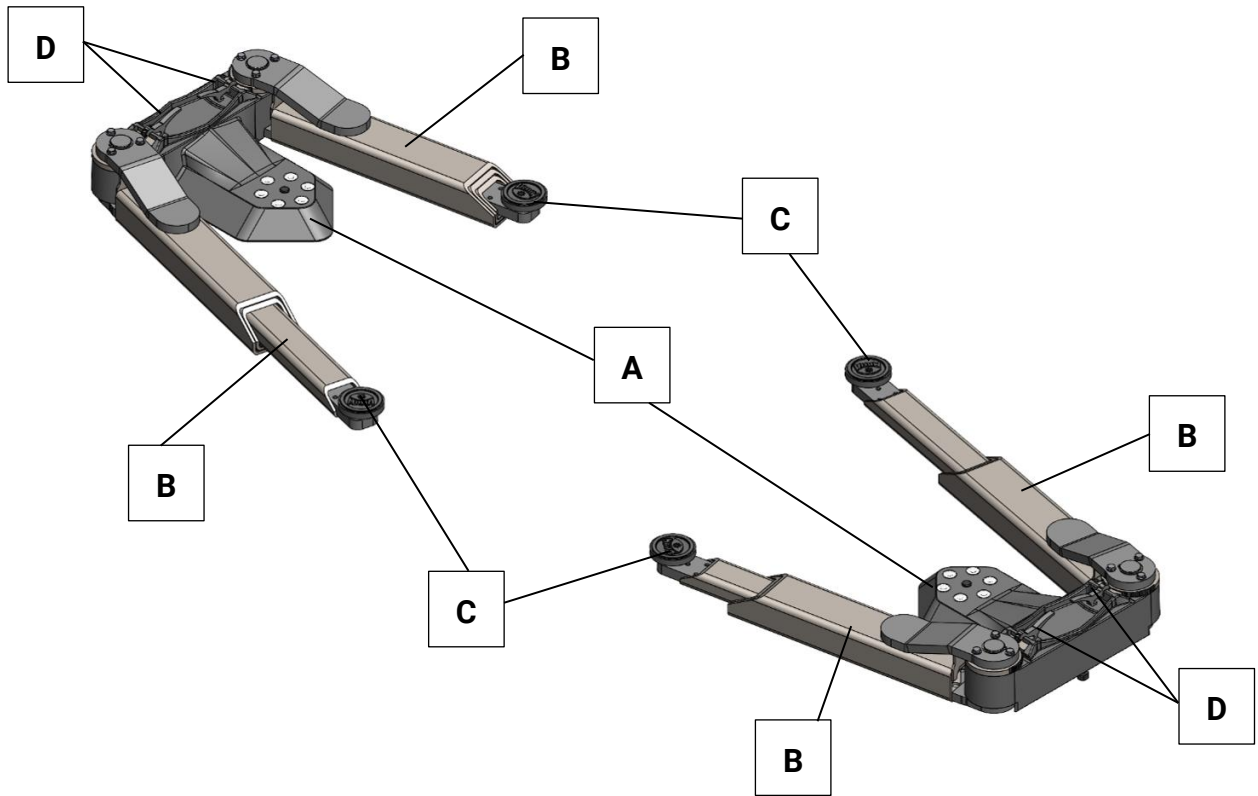

A Swing arm carrier

B Support arm, telescopic

C Support plate

D Lock

2.4 Technical Data

2.4.1 Danger Zone

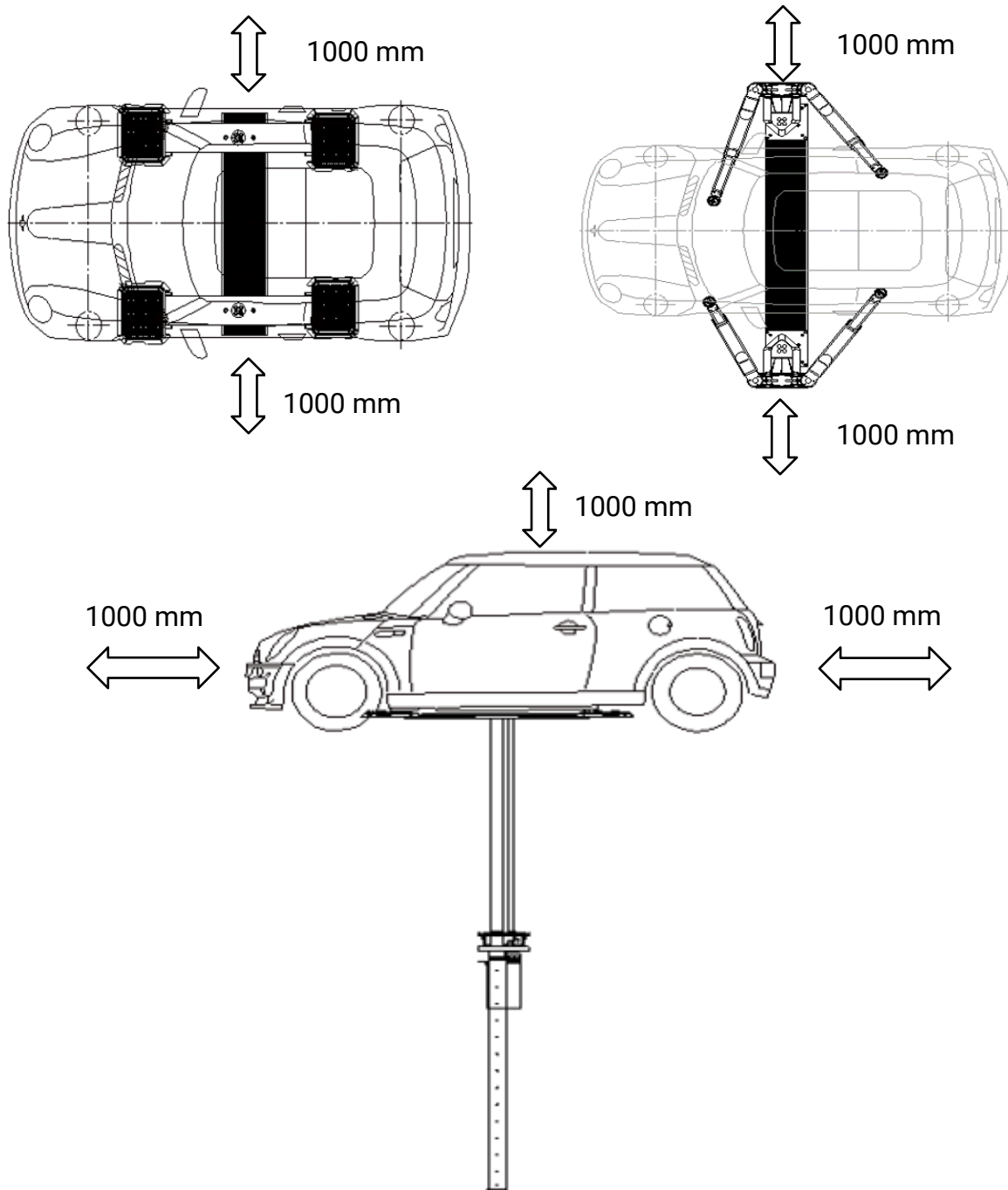

2.4.2 Technical Data

ZS DUETT model	3.5 FT	3.5 GS	4.5 GS	5.0 GS
Rated load capacity [kg]	3500	3500	4500	5000
Stroke height [mm]*	1900	1868	1868	1868
Installation depth incl. installation box T [mm]*	2395	2395 2690	2395 2690	2395 2690
Post spacing SA [mm]*	1350	2500	2500	2500
Clear width between lifting units LW [mm]*	SA – 200 SA – 535	SA – 400	SA – 400	SA – 400
Overall width head plate-head plate KK [mm]*	SA + 200 SA + 265	SA + 400	SA + 400	SA + 400
Max. length of support arm ITr max [mm]*	---	1170	1600	1700
Operating temperature [°C]	+5...+40			
Drive power [kW]	3,0			
Duty cycle	S3-20%			
Power supply	3x 400 V, PE, 50/60 Hz 3x 230 V, PE, 50/60 Hz			
Fuse	gG 16 A			
Hydraulic oil specification	HLP-D 22 (HLP-D 22 Synth)			
Operating pressure [bar]	40	21	40	40
Filling quantity of hydraulic power unit [L]	56	103	96	96
Lifting and lowering time [s] (load-dependent)	38			
Sound pressure level [dB(A)]	< 70			
Net weight of lift approx. [kg]*	700	900	1400	1450

* The values given here refer to the standard version. Depending on selected options or special adjustments, these values may vary.

Legend:

FT = Flat head support

GS = Swing arm support with cast steel carrier

2.4.3 Set-up Diagrams

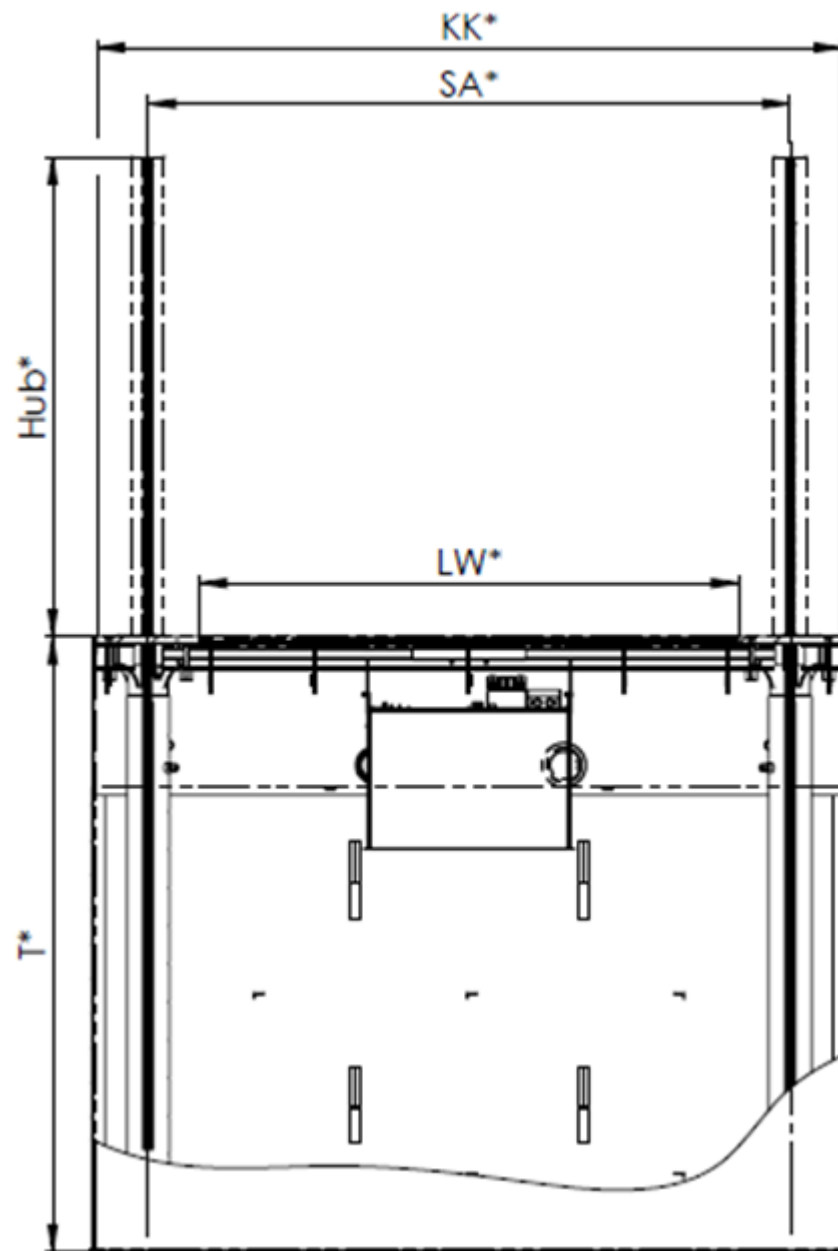

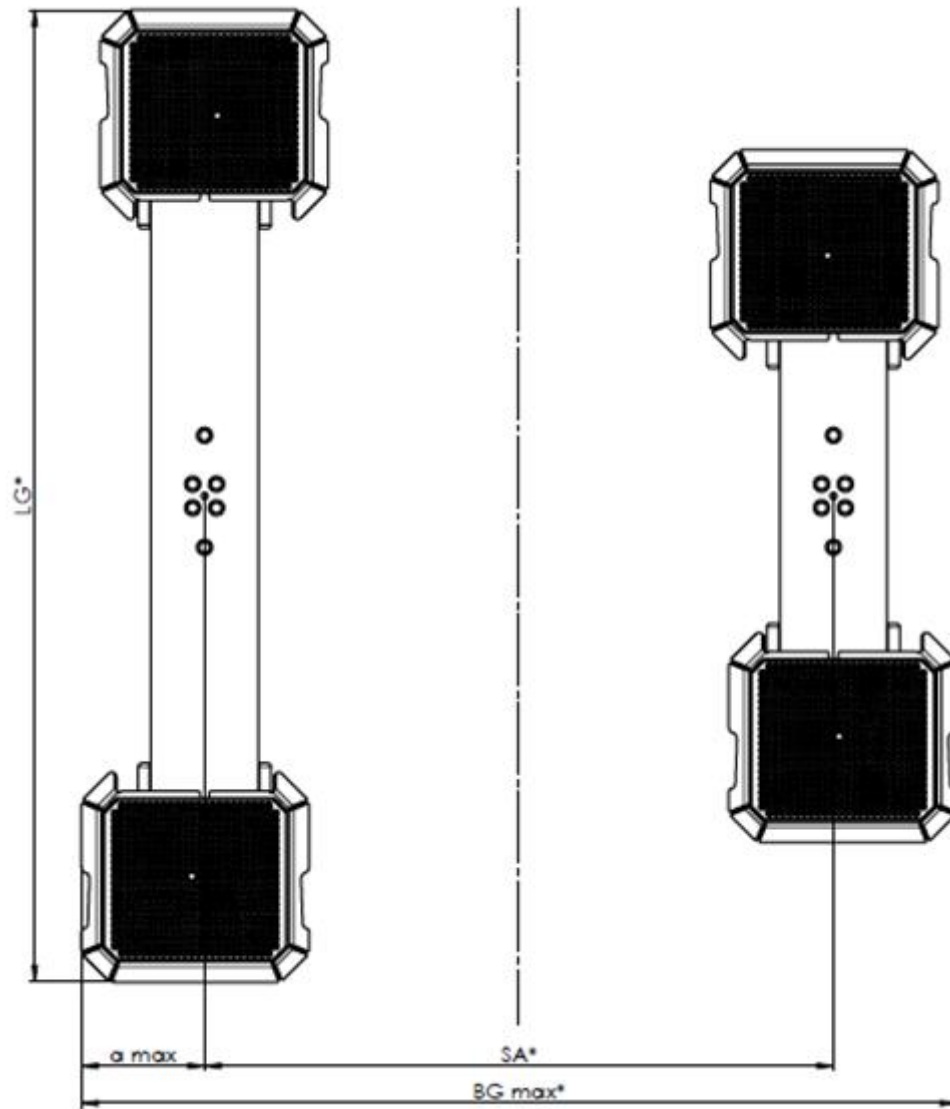

ZS DUETT model	3.5 FT		
	Standard	Long	Wide
Pull-out	Standard	Long	Wide
a max* [mm]	265	265	405
BG max* [mm]	SA + 530	SA + 530	SA + 810
LG* [mm]	2086	2286	2086

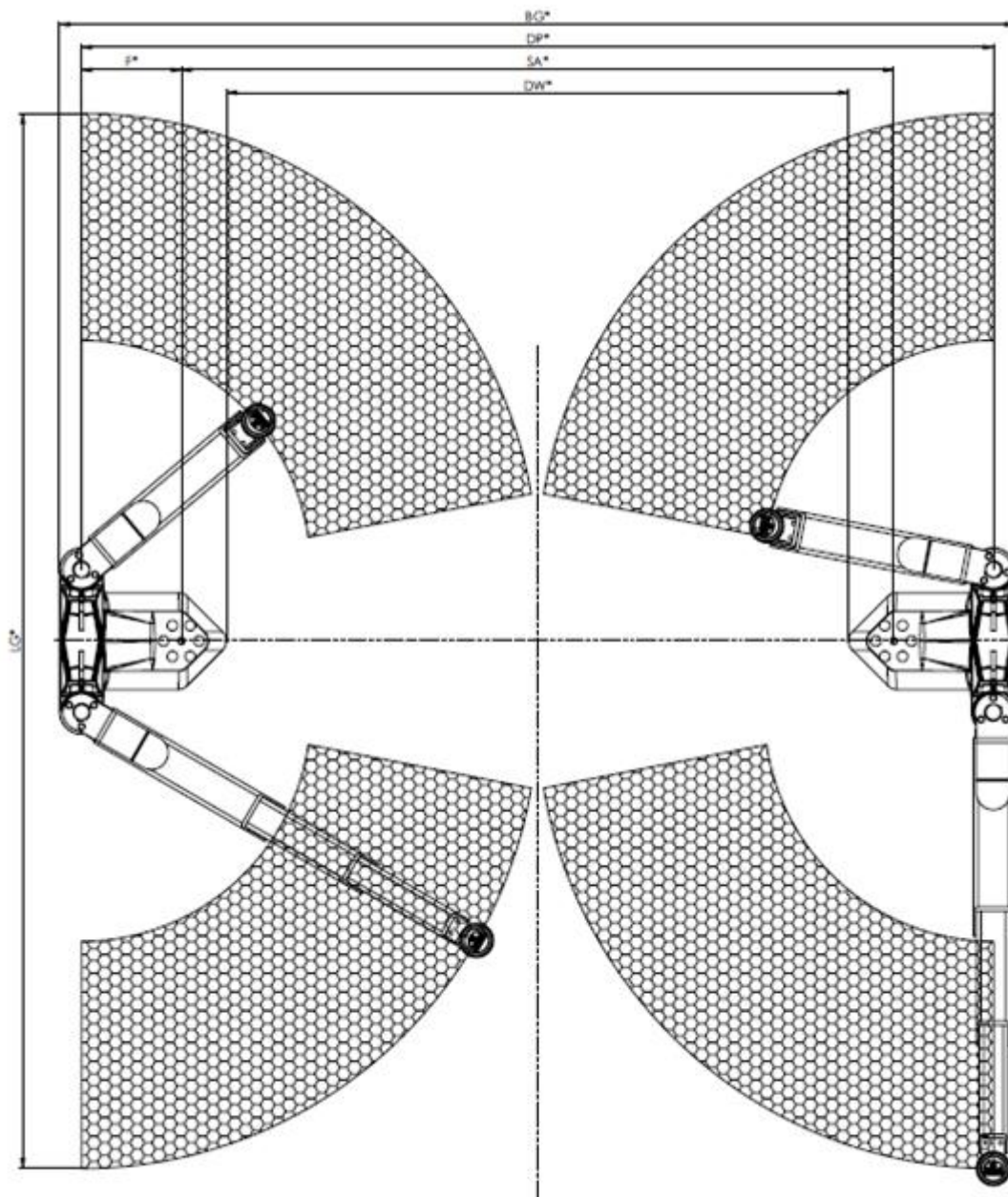

ZS DUETT model	3.5 GS			4.5 GS		5.0 GS	
F [mm]	100	200	575	350	925	350	925
BG* [mm]	SA + 352	SA + 552	SA + 1360	SA + 852	SA + 2030	SA + 852	SA + 2030
DP* [mm]	SA + 2xF						
DW* [mm]	SA - 320	SA - 320	SA - 250	SA - 320	SA - 256	SA - 320	SA - 256
LG* [mm]	2820			3700		3900	

3 Transport, Handling and Storage

3.1 Safety Instructions



WARNUNG

- Wear personal protective equipment.
 - Standing under a suspended load is prohibited.
 - Transport and storage of packages is allowed only in original packaging
 - Before removing the packaging straps, secure the packages against falling and maintain a safe distance. Rebounding packaging straps can cause injuries!
 - When handling the packages, always observe the center of gravity position (COG marking).
 - Only use lifting equipment and slings that are suitable in terms of type and permitted load capacity. The weights are to be taken from the transport documents.
 - Always ensure that the parts to be transported are suspended or loaded properly and in a fall-proof manner, taking into account their size, weight and centre of gravity. Observe transport regulations.
 - The individual packages are not stackable.
-

3.2 Transport, Handling and Storage

Transport and handling of the lifts are only permitted in the original packaging. The packages must be stored in a covered location and protected from direct sunlight. They must be stored at low humidity and at a temperature between 0 °C and +40 °C.

Packaging waste must be disposed of in accordance with applicable environmental regulations.

4 Operation

4.1 Safety Instructions



WARNING

- Comply with legal accident prevention regulations.
- Wear personal protective equipment.
- Carry out visual and operational checks daily before the commencement of work (see also section “Inspection and maintenance schedule”).
- Defects must be corrected immediately in a competent manner.
- The permissible load capacity according to the type plate must not be exceeded.
- Only vehicles suitable for the lifting equipment due to their shape and the positioning of their pick-up points may be lifted.
- Vehicles must be lifted as a whole. Use of external lifting and support accessories in conjunction with the lift is prohibited.
- Operation of the lift is only permissible with mounted and intact protective covers and safety devices.
- Never touch moving parts.
- Never use an additional lifting gear for an already raised load.
- No persons are allowed in the danger zone when driving onto or off the lift.
- Before driving onto the lift, all parts of the support must be in the lower basic position.
- Arms of swing arm supports must be swiveled back completely. Otherwise damage to the equipment may occur.
- Only drive on the lift at walking speed, if possible in the centre between the cylinders.
- Vehicles may only be lifted with support arm locks intact and undamaged support discs. Risk of vehicle falling and causing personal injury.
- Support disc raisers may only be used in their single form. A combination of support disc raisers per support disc is not permitted.
- Maintain a safe distance from the vehicle and lift in all directions.
- Keep the movement range of the load and lift free from obstacles. Use a guide if visibility is restricted.
- The operating panel (optional) must be positioned in such a way that the entire working area can be overviewed and the emergency-off or emergency-stop actuators are easily accessible.
- Vehicle doors must be closed during lifting and lowering.
- The vehicle must be strapped to the lift if necessary. Shifts in the centre of gravity of the vehicle through installation/removal of heavy vehicle parts may otherwise lead to the vehicle sliding off.

- After raising just off the floor, check that the vehicle has been picked up securely and that the support arms are locked correctly. If necessary, lower the vehicle and pick up again.
 - If the vehicle has been lowered to the ground, check that it has been picked up securely before lifting it again.
 - The transport of passengers is prohibited.
 - Climbing on the raised vehicle or on the lift is prohibited.
 - No persons or objects are allowed within the safety zone of the lift and the load during the lifting and lowering process.
 - Monitor the load and the lift during lifting and lowering. In the event of irregularities, one of the emergency stop switches must be actuated immediately (main switch on the control box or emergency stop button on the cable remote control).
 - Parts must not be placed on the lift or the vehicle to be lifted.
 - Keep the lift and the working area clean. ATTENTION: Risk of slipping on oily surfaces!
 - Lighting of the work station is the operator's responsibility.
 - Protect all parts of the electrical system from moisture.
 - Be careful when running vehicle engines. ATTENTION: Risk of poisoning!
 - Changes to or overriding of the safety features installed is prohibited!
 - Inching mode should be avoided to prevent the motor from overheating. Instead, drive briskly through.
 - During work breaks and at the end of the working day, the system must be switched off and secured against unauthorised use.
 - Before leaving the lift, the lifted vehicle must be fully lowered or secured against inadvertent lowering.
-

4.2 Preparations

4.2.1 Initial Position/Ready for Operation

- The main switch must be at position 0.
- The lift must be lowered all the way down.

Preparing the support: Flat head support

- The pull-outs must rest fully on the flat head support.
- The grooved pin mounted in the flat support must engage in the pull-out.

Preparing the support: Swing arm support

- The support arms must be swiveled completely out of the working area.

4.2.2 Positioning of the Vehicle

- 1 Carefully drive the vehicle forward and centrally between the lifting cylinders and secure it against rolling away.

- 2 The vehicle's centre of gravity should be as centered as possible between the lifting cylinders.

4.2.3 Positioning of the Supports

Flat head supports

Lift the pull-outs at the front and move them so that the pull-outs are positioned as accurately as possible under the pick-up points. The notched pin must engage in one of the holes in the pull-out.



CAUTION

- The notched pin must *not* be positioned in the rectangular cutout (A).

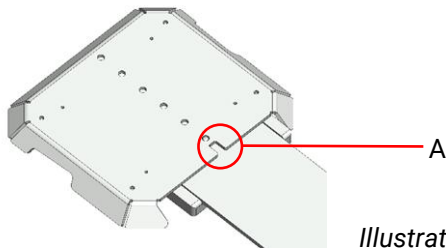

- The pull-out must rest fully on the flat head support.

- 2 For granulate-coated pull-outs, place rubber blocks (original accessories) between the support points and the pull-out. The use of rubber blocks is optional for pull-outs with rubber pad.



CAUTION

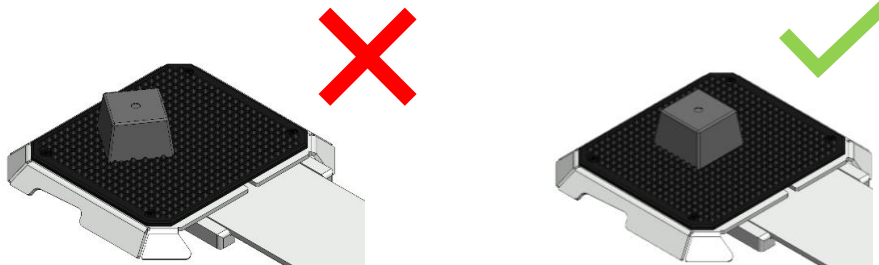

- When using nubbed rubber pads, the rubber blocks must snap into place.

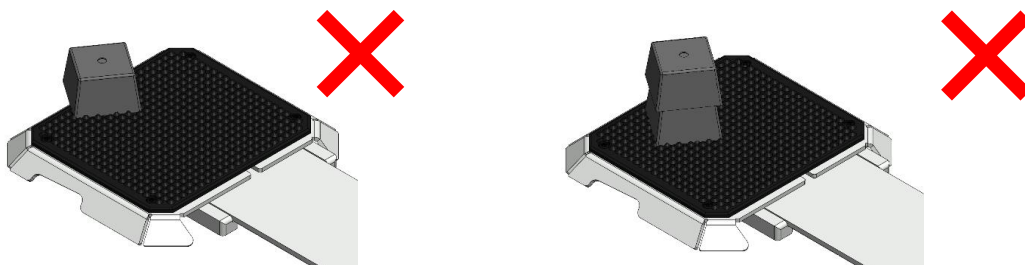

- Rubber blocks must generally not protrude above the pull-out.
- Accessories for flat head supports (e.g. rubber blocks) must generally not be stacked.

Swing arm supports

- 1 By swiveling and pulling out the support arms, bring the support discs under the support points specified by the vehicle manufacturer.
- 2 Rotate the support discs so that all four support points are reached evenly.
- 3 Use support disc raisers as required.



WARNING

The support disc raisers are only available for a load of 4500 kg and higher. The maximum load of 1500 kg per support disc raiser must not be exceeded.

The support disc raisers (partially optional) are available in lengths of 50 mm, 100 mm, 150 mm, 200 mm and 300 mm.

By inserting the support disc raisers, the support discs can be adjusted in increments of 50 mm. Fine adjustments are possible by turning the support disc.



CAUTION

- Only **one** raiser may be used per support disc.
 - The anti-rotation lock, which consists of a groove and a dowel pin inserted into a sleeve, must always be engaged.
-

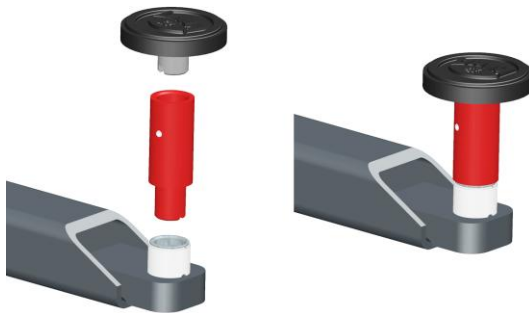

4.3 Raising and Lowering Cycles



WARNING

When installing or removing heavy vehicle components, ensure that the centre of gravity does not shift to a dangerous extent! The vehicle may tip off the lift. The vehicle must be secured against tipping by suitable means.

4.3.1 Control Elements

The buttons of the control elements are assigned with the following functions:

Small control element

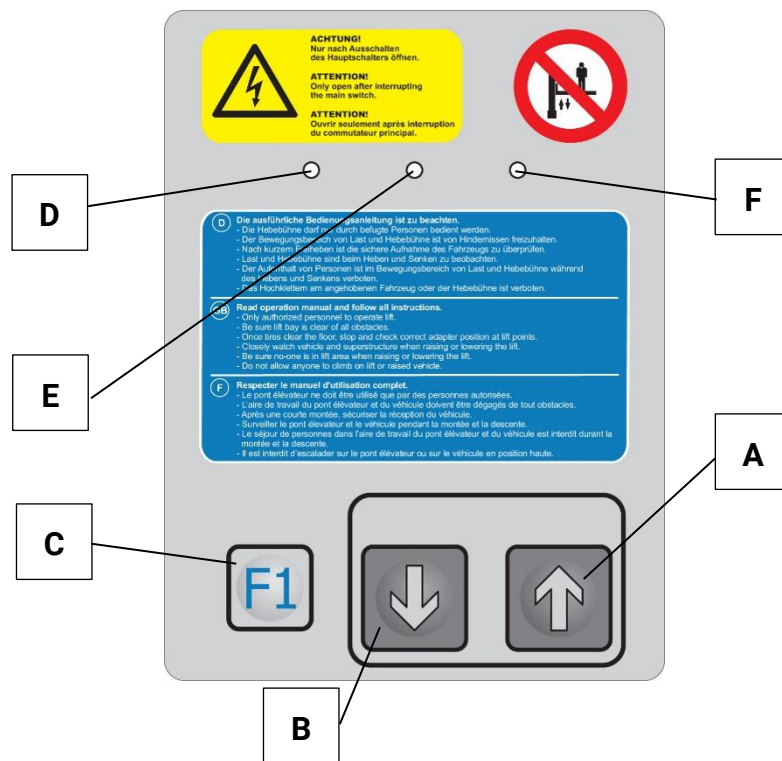

	Function	Short form	Comments
A	Raise the lift	LIFT UP	---
B	Lower the lift	LIFT DOWN	---
C	Multifunction key 1	F1	without function, only for service personnel
D	LED light, red: Malfunction or error code	---	see section "LED signal codes"
E	LED light, yellow: Warning or error code	---	see section "LED signal codes"
F	LED light, green: Ready for operation	---	---

Large control element

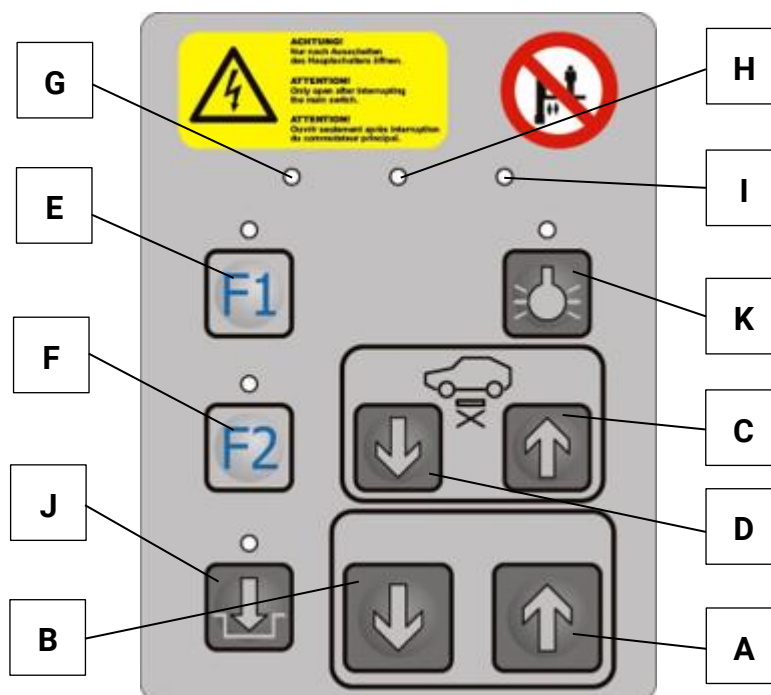

	Function	Short form	Comments
A	Raise the lift	LIFT UP	---
B	Lower the lift	LIFT DOWN	---
C	Lift wheel-free jack	WFJ UP	---
D	Lower wheel-free jack	WFJ DOWN	---
E	Multifunction key 1	F1	without function, only for service personnel
F	Multifunction key 2	F2	without function, only for service personnel
G	LED light, red: Malfunction or error code	---	see section "LED Signal Codes"
H	LED light, yellow: Warning or error code	---	see section "LED Signal Codes"
I	LED light, green: Ready for operation	---	---
J	Floor compensation – is always lowered = LED on; – is lowered below the pinch protection, raised above = LED off	FLOOR	---
K	Lighting – switches on above the pinch protection, off below = LED on – is always off = LED off	---	---

4.3.2 Approaching the Vehicle and Checking for Safe Pick-up

- 1 Set the main switch to position I.
- 2 Press the UP button until the supports are in contact with the support points of the vehicle.
- 3 Check the position of the supports and correct it if necessary.
For swing arm supports: Check that support arms lock securely. If necessary, move the support arms slightly until the toothed segments are engaged.



CAUTION

The support arm lock must not be operated under load.

- 4 Continue the lifting process pressing the UP key to the desired lifting height.

4.3.3 Lowering Process and CE Stop

- 1 Before lowering the vehicle, remove tools, support blocks or similar obstacles from under the vehicle. The operator is responsible for ensuring that nobody is within the danger area.
- 2 Press and hold the DOWN button until the desired lifting height is reached.
- 3 The lowering process stops automatically when the CE stop height is reached.
- 4 For complete lowering to the home position, release the DOWN button after reaching the CE stop and press it again. When lowering below the CE stop height, an additional acoustic signal sounds.

4.4 Driving off the Lift and Changeover

- Lifts with swing arm supports: After the lift has been lowered completely, turn the support arms out to the side and bring them back into home position.
- All supports: Then drive the vehicle off the lift.



WARNING

Contact of the support arms with the wheels or other vehicle parts during drive-off can cause damage to the support arm lock. A resulting consequence can be the loss of function of the support arm lock.

Conversion of flat head pull-outs

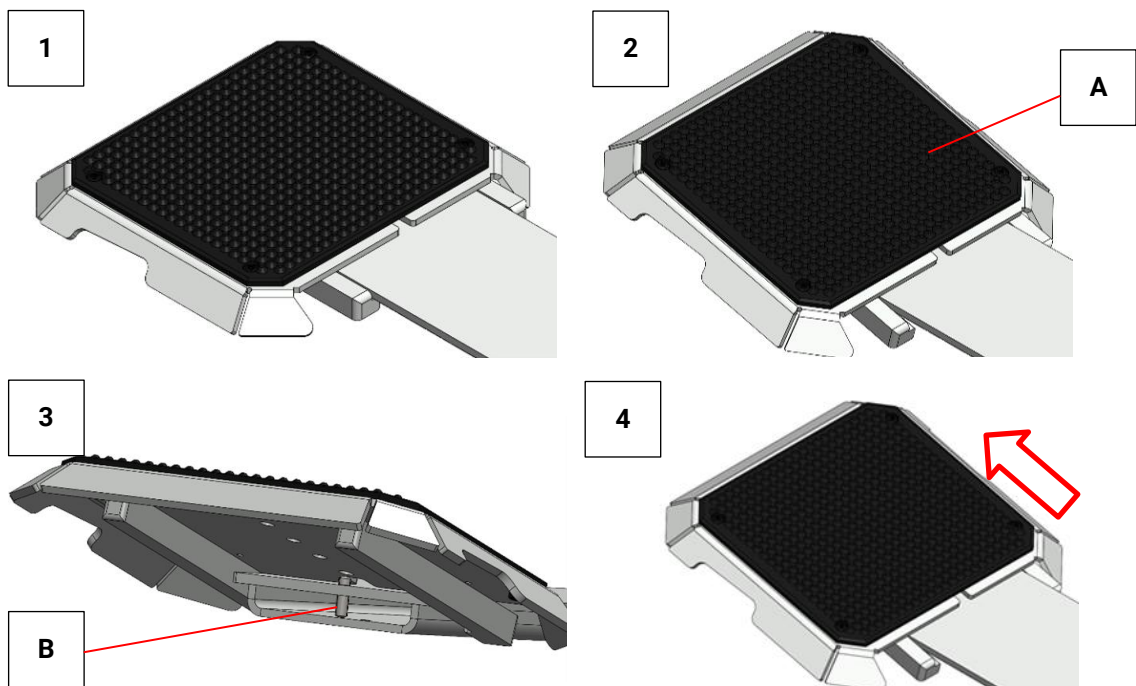

- 1 Extend the lift approx. 50 cm.
- 2 Lift the pull-out (A) upwards until the grooved pin (B) no longer engages in the pull-out.
- 3 Lift the pull-out (A) slightly and pull it away to the front via the grooved pin (B).
- 4 Install the new pull-out (C) in reverse order.

4.5 Emergency Lowering



WARNING

In the event of an emergency lowering, the safety devices of the lift are completely or partially overridden. Emergency lowering may only be performed by trained personnel.

The lift must not be put back into operation until the fault has been rectified.

In the event of an electrical or mechanical malfunction, two emergency lowering options are available for the lift.

4.5.1 Electric Emergency Lowering

The electric emergency lowering is identical for all lifts of this series.

- 1 Set the main switch on the control box to position "0".
- 2 Open the control box.
- 3 Pull the standard plug **(B, C)** from the 4-pin connector block marked X5 **(A)** and insert the plug of the emergency stop cable X5.1 in its place **(D)**.
- 4 Clamp the other end of the emergency lowering cable with the alligator clips to two 12 V car batteries connected in series **(E)**.
- 5 The lift can be lowered via the control element **(F)**.

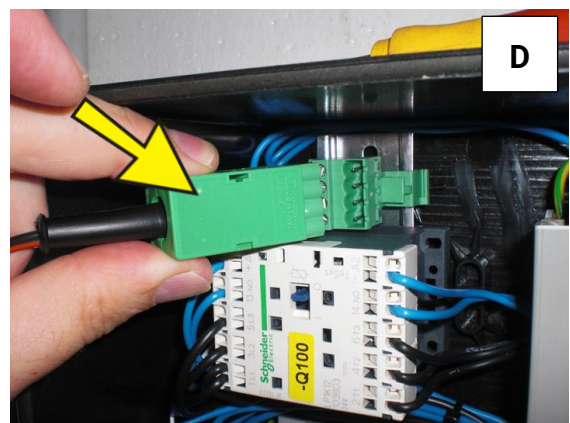
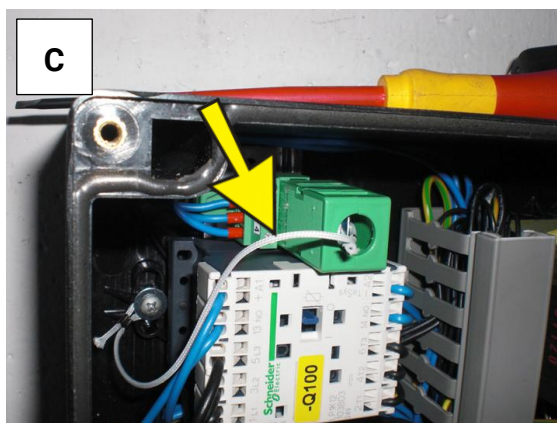
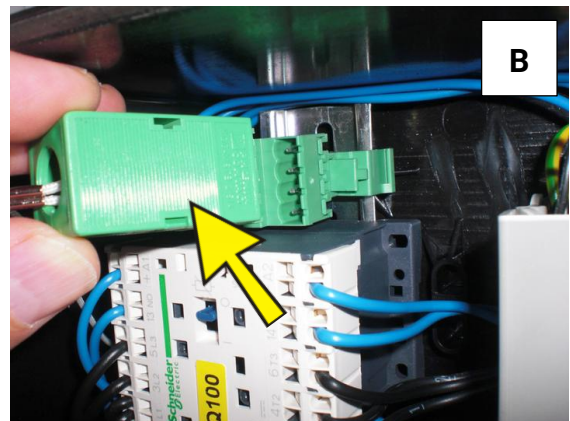
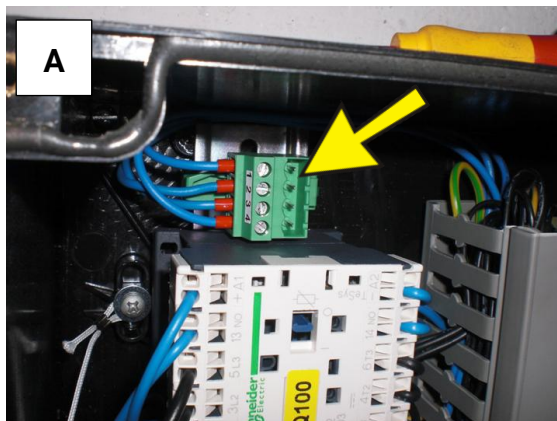

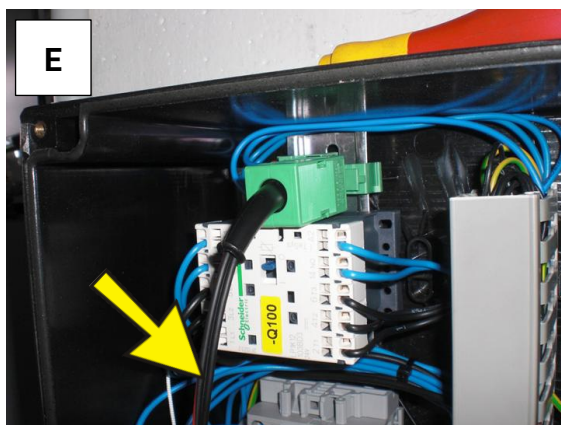

4.5.2 Mechanical Emergency Lowering

The mechanical emergency lowering takes place via the bleeding blocks of the lifting units.

ZS DUETT 3.5 FT

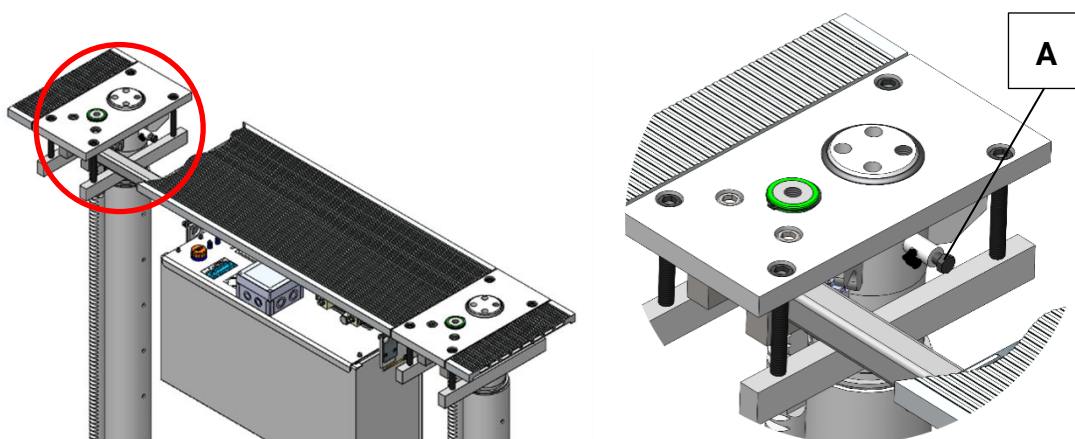

- 1 Remove the centre cover.



WARNING

The lift lowers on one side by about 50 mm. As soon as the hex screw (A) (A/F 19) on the second lifting unit is opened, the lift lowers. Leave the danger zone directly!

- 2 On the first lifting unit, slowly open the hex screw (A) (A/F 19) on the bleeding block by no more than one turn.
- 3 On the second lifting unit, slowly open the hex screw (A) (A/F 19) on the bleeding block by no more than one turn.
- 4 Once the lift is completely lowered, slowly drive off the vehicle.
- 5 Tighten the hex screws (A) (A/F 19) on both lifting units to a tightening torque of 10 Nm.
- 6 Close centre cover.

ZS DUETT 3.5 GS / ZS DUETT 4.5 GS / ZS DUETT 5.0 GS

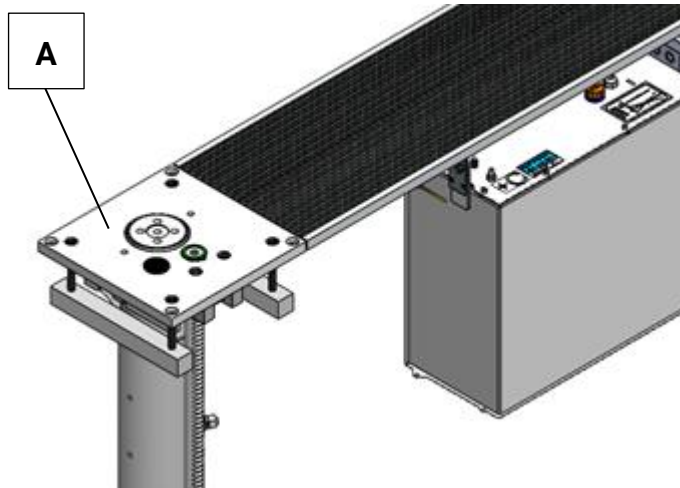

- 1 Remove the sealing plug (A).



WARNING

The lift lowers on one side by about 50 mm.
As soon as the threaded pin on the second lifting unit is opened, the lift lowers.
Leave the danger zone immediately!

- 2 Slowly open the threaded pin (A/F 6) located underneath by no more than one turn.
- 3 Slowly open the threaded pin (A/F 6) in half-turn increments.
- 4 Once the lift is completely lowered, slowly drive off the vehicle.
- 5 Tighten the threaded pins (A/F 6) on both lifting units with a tightening torque of 10 Nm.
- 6 Press the sealing plug (A) back in.

4.6 Optional Equipment

4.6.1 Hinged Cover Frame

To lower lifts with swing arm supports to floor level, they can be supplied with a hinged cover frame.

NOTICE

The hinged cover frame must be set in concrete with the installation box. A subsequent installation is no longer possible.

Before the lift can be driven on with a vehicle, the following preparations must be made:

- 1 Turn the main switch to position "I".
- 2 Remove filler pieces for the closed state (A).
- 3 Open the hinged cover (B) and extend the lift by pressing the UP button for approx. 1 m.

- 4 Close the hinged cover (B) and insert the filling pieces for the open state (C).
- 5 Retract the lift completely by pressing the DOWN button.

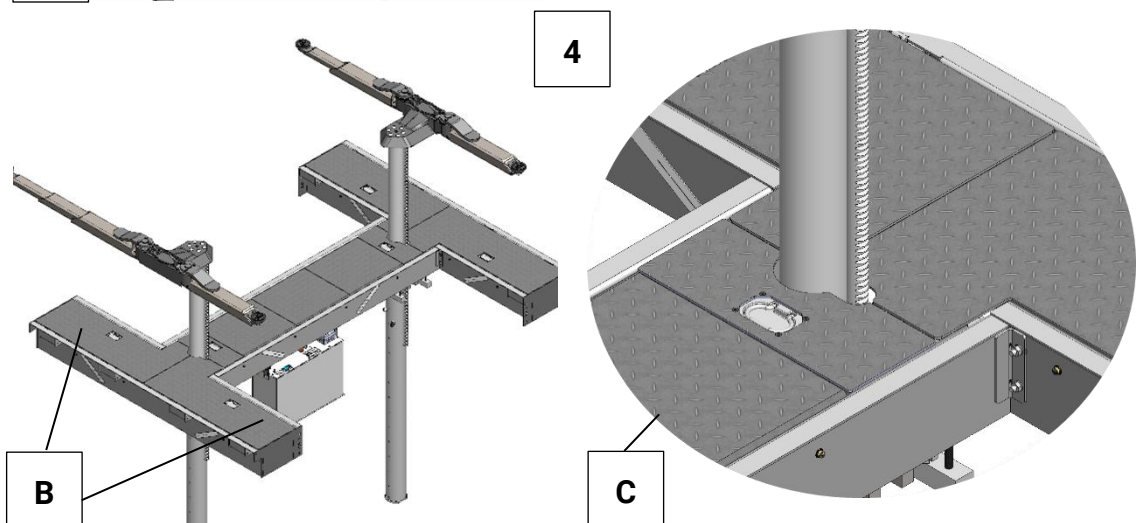
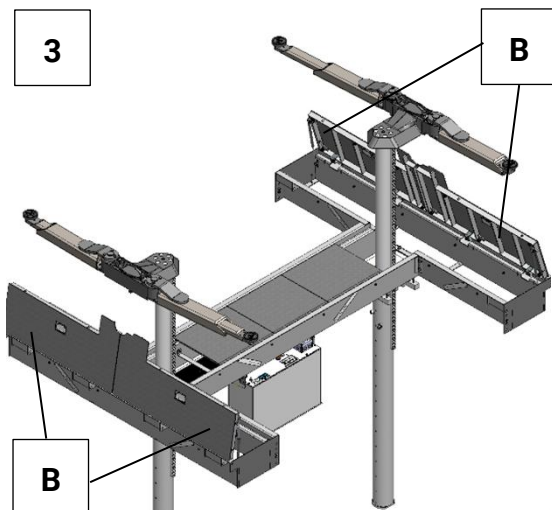
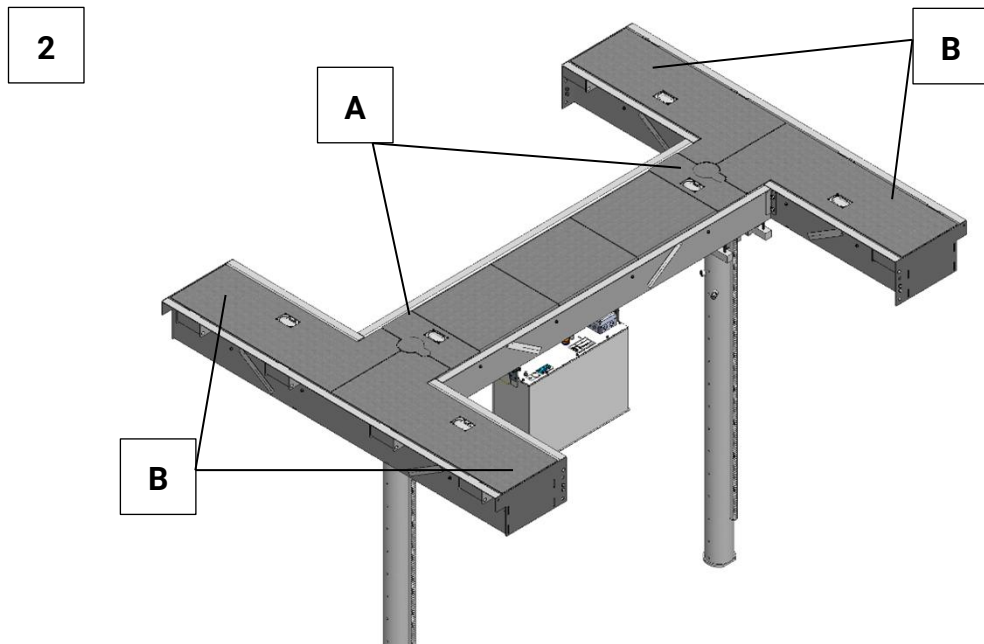

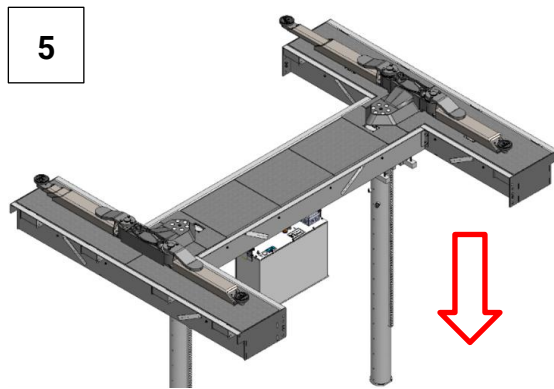

4.6.2 Installation Frame for Flat Head Lifts



CAUTION

In this installation situation, there is no floor compensation; when raised, this results in additional tripping hazards. This must be observed when working on the vehicle.

4.6.3 Wheel Engaging Support

Lifts with a nominal load capacity of 4500 kg and above can be equipped with wheel engaging supports as an alternative to the disc supports.

The lift is designed according to EN 1493, which specifies a total load capacity and takes into account an asymmetrical load distribution. When using the wheel engaging supports, it should be noted that the vehicle weight with asymmetrical load distribution is no longer decisive, but the individual load-bearing capacity of 1,000 kg per wheel engaging support:

- **Maximum wheel load 1000 kg**

For the conversion, remove the threaded sleeves and install the wheel engaging supports as shown below.

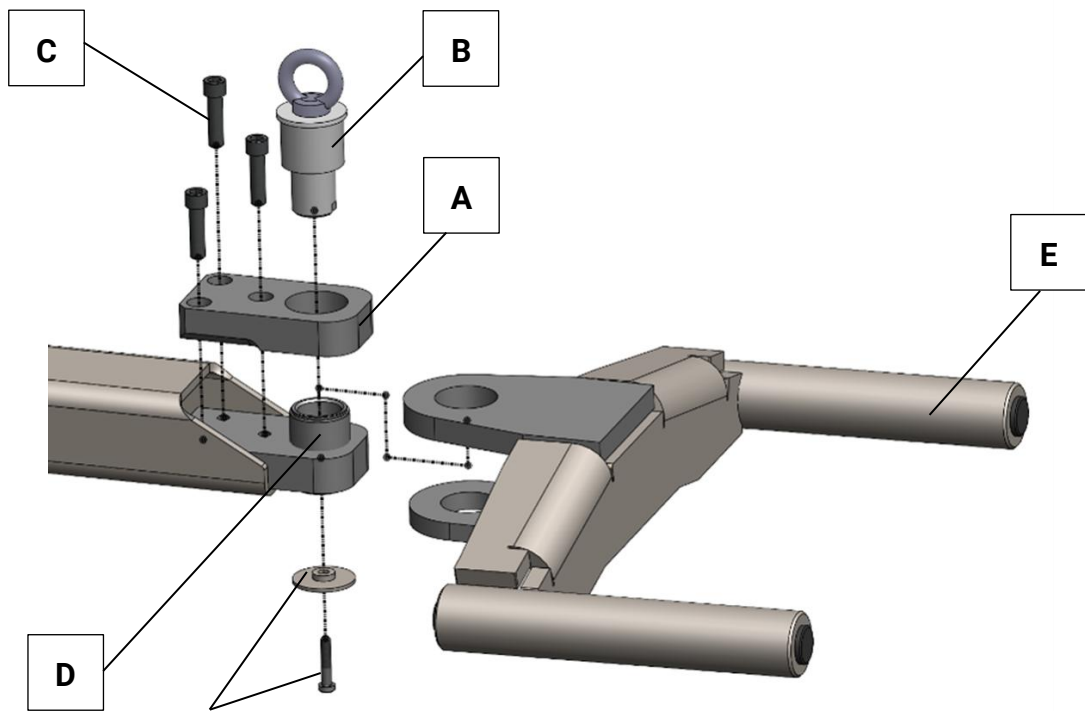

A	Guide plate	D	Threaded sleeve
B	Support pin	E	Wheel engaging fork
C	Fastening screws M12x45 10.9	F	Fastening screw with washer

NOTICE

Lightly grease the sliding surfaces before mounting the wheel engaging supports.

- 1 Screw the support disc all the way down (protruding at the bottom) and remove it.
- 2 Position the guide plate (A) and insert the support pin (B).
- 3 Screw in fastening screws (C) and tighten them hand-tight. Make sure that there is no tension between support pin and guide plate.
- 4 Torque the screws to 120 Nm.
- 5 With the support pin inserted, turn the threaded sleeve (D) upward until it is flush with the guide plate.
- 6 Pull the support pin and fit the wheel engaging fork (E).
- 7 Fully insert the support bolt and turn it down completely.
- 8 Secure the support pin with the fastening screw and washer (F).

4.6.4 Special Prism Support – Plug-in System



*Special prism support
for MB G-class without tread plate*

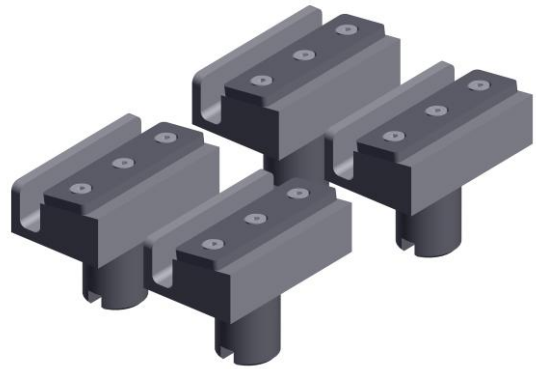

*Special prism support
for MB G-class with tread plate*



WARNING

When using the special prism support with or without a tread plate, the rated load capacity is 3,500 kg.

4.6.5 Additional Jointed Arm

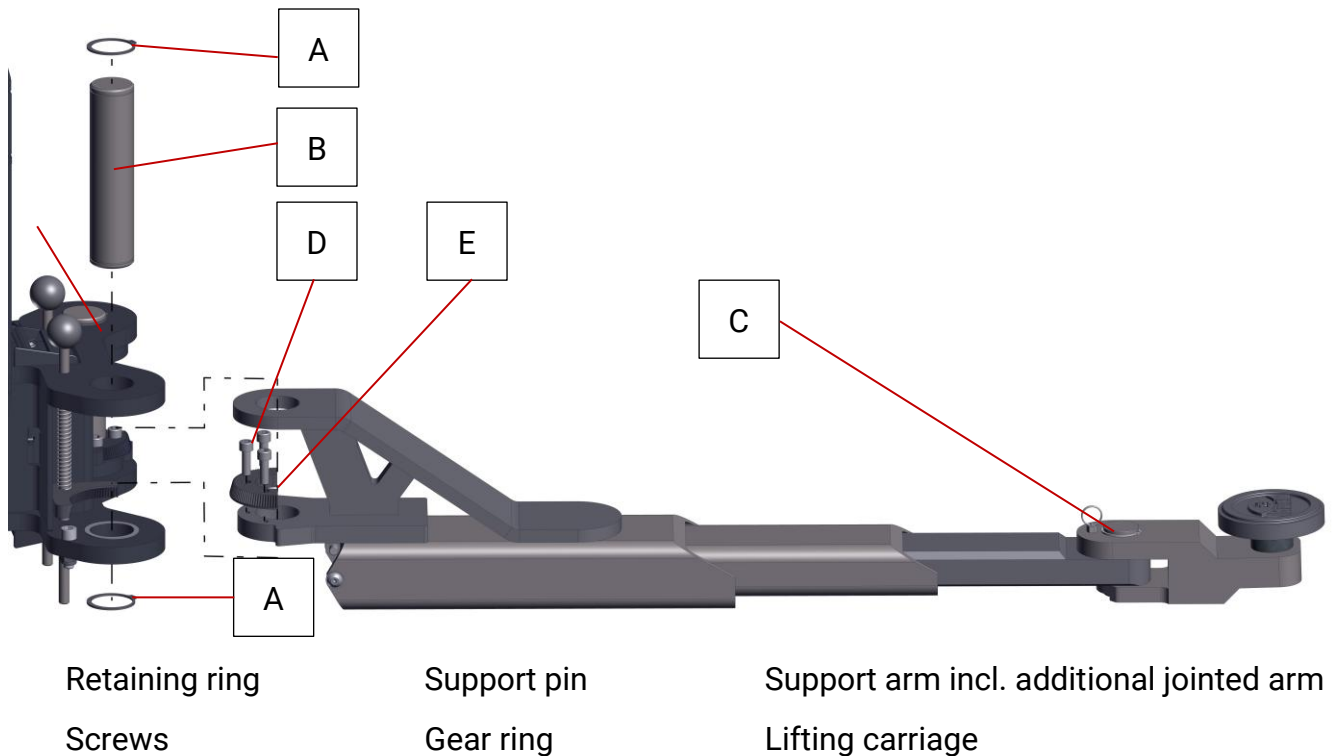

Furthermore, lifts with a rated load capacity of 3500 kg can be fitted with a support arm including an additional jointed arm.

Swivelling the additional jointed arm improves access to the vehicle's lifting points, as well as accessibility to the vehicle.

To retrofit the support arm with the additional jointed arm, carry out the following steps:

- 1 The lift is at a height of 1000 mm and is switched off (main switch off).
- 2 Secure the support arm (C) against falling using suitable means or place a support underneath
- 3 Remove both retaining rings (A) from the support pins (B).
- 4 Remove the support pin (B) from the lifting carriage.
- 5 Remove the support arm (C).
- 6 Remove the screws (D) to dismantle the gear ring (E).
- 7 Fit the screws (D) and the ring gear (E) to the support arm incl. additional jointed arm (C).
- 8 Lift the support arm incl. additional jointed arm (C) back onto the lifting carriage and insert the support pin (B).
- 9 Fit the retaining rings (A).

The components of the support arm are shown in detail below.

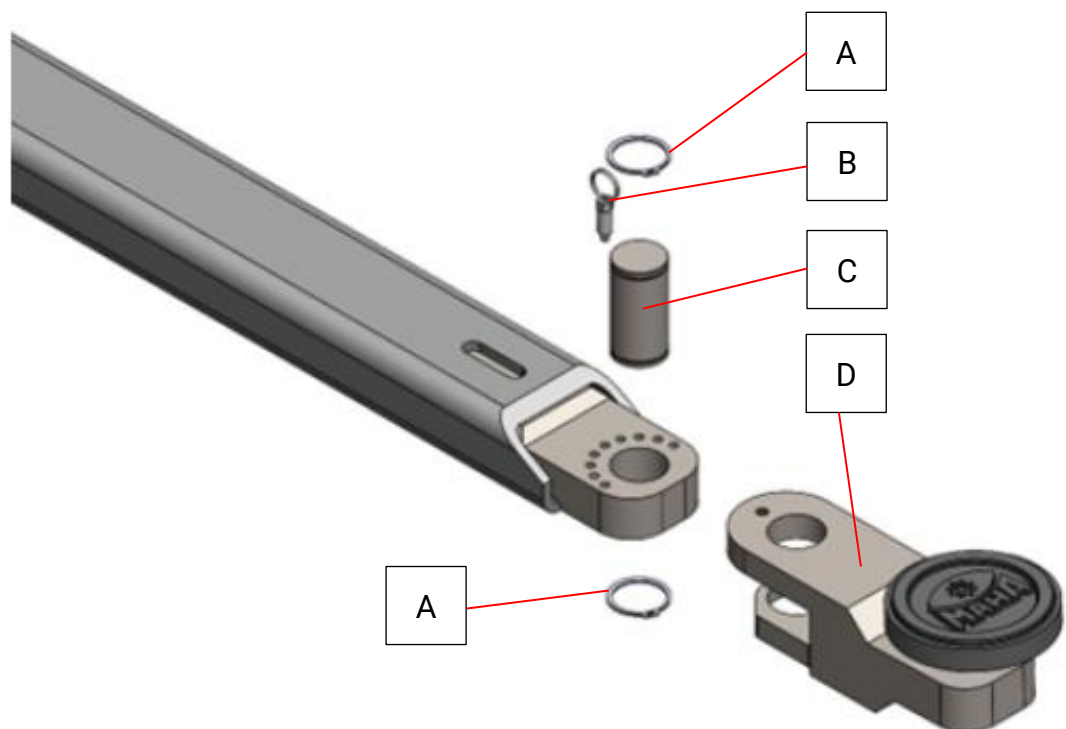

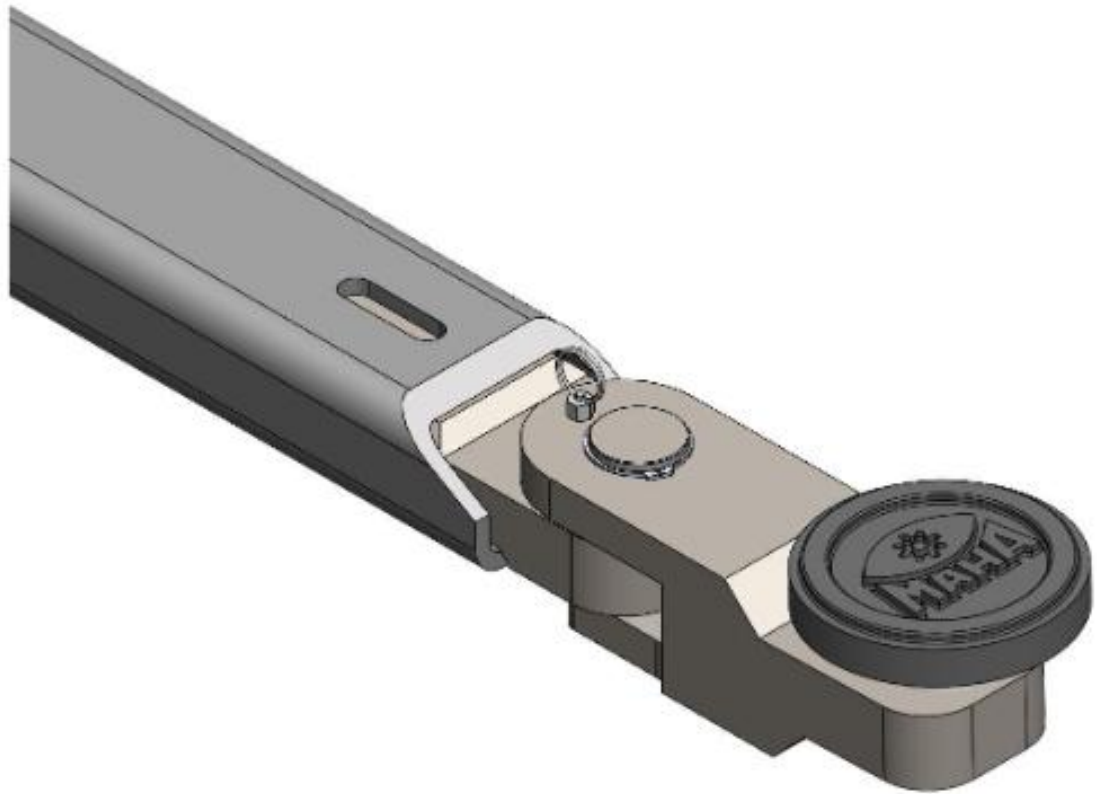

A Retaining ring

B Locking pin

C Support pin

D Additional jointed arm



CAUTION

- The additional jointed arm lock must not be operated under load.
 - The locking pin (B) must be securely engaged.
-

Operating the additional jointed arm

- 1 Pull the ring on the locking pin (B) and, whilst holding it in this position, adjust the angle of the additional jointed arm (D).
- 2 Release the locking pin and move the additional jointed arm (D) until the locking pin (B) engages noticeably in one of the holes.

4.6.6 Support Disc System (ATS)

The support disc system can be used in conjunction with swing arm lifts. This system allows the use of specific vehicle supports and can also be used for battery handling on electric vehicles.



WARNING

- The “Safety Instructions” section must be observed with particular care.
 - When using specific vehicle supports, they must always be in full contact with the surface.
 - Specific vehicle supports must not be used without the support disc system.
 - The manufacturer-specific vehicle supports must be used in accordance with the vehicle manufacturers’ application specifications.
-

a. Claw support disc

The claw support disc (A), in combination with the standard support disc (B), enables the use of the PAD support / ATS (C). To do this, the claw support disc must be pressed onto the standard support disc vertically and so that it makes full contact.

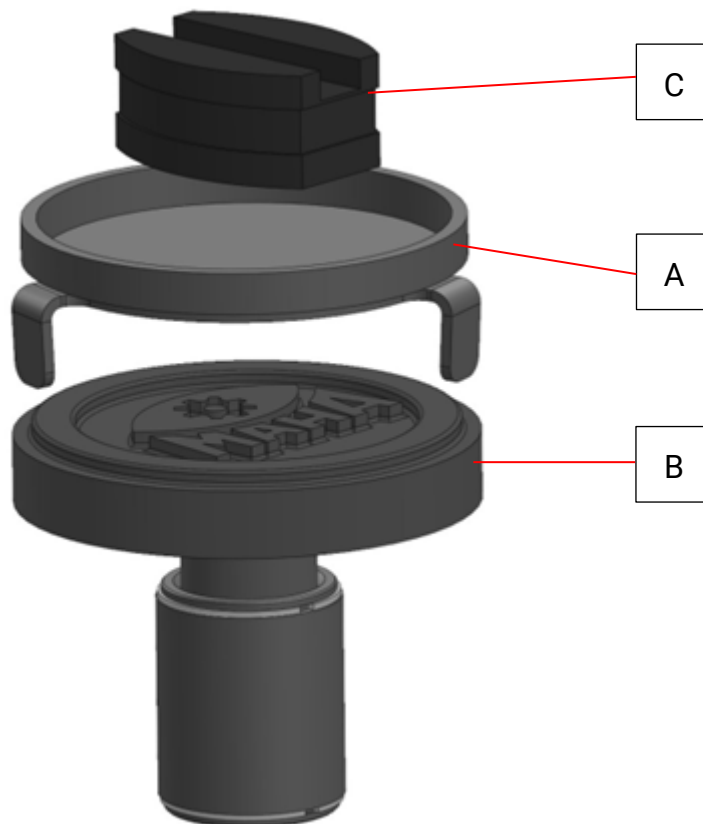



WARNING

When using the claw support disc, it must rest flat on the standard support disc with rubber pad.

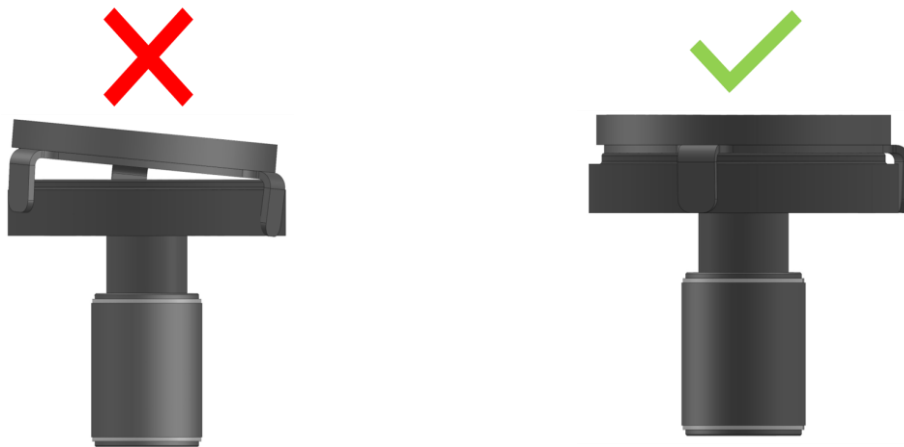

b. Support disc for threaded insert

The support disc for threaded insert (B), in combination with the standard threaded insert (A), enables the use of the support disc system. To do this, the standard support disc must be removed from the threaded insert. The support disc for threaded insert can be inserted into the standard threaded insert after removing the original support disc.

The support disc for threaded insert shown here is an example applicable to all manufacturer-specific special steel replacement inserts.



WARNING

Ensure that the groove of the support disc for threaded insert engages with the pin of the standard threaded insert.

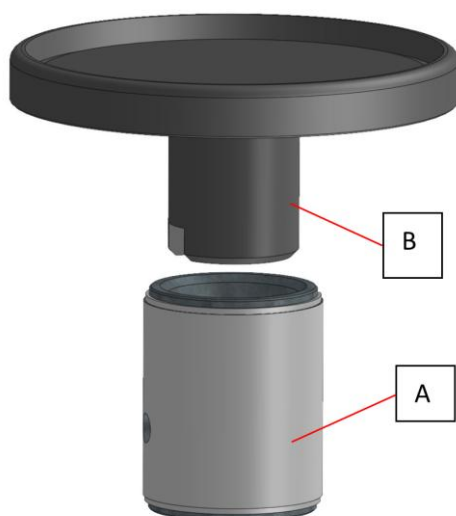

A Threaded insert

B Support disc

c. Spring support with support disc

The spring support with support disc enables the use of the support disc system.

The following steps must be followed for installation:

- 1 The lift is in the initial position; see section "Initial Position/Ready for Operation".
- 2 Remove the standard support disc.
- 3 Remove the upper or lower snap ring from the standard threaded insert.
- 4 Unscrew the standard threaded insert.
- 5 Screw in the threaded insert for the spring support.
- 6 Secure the threaded insert of the spring support with the two snap rings (C).
- 7 The standard support disc with rubber pad, the support arbor and the support disc with granulate coating are permitted.

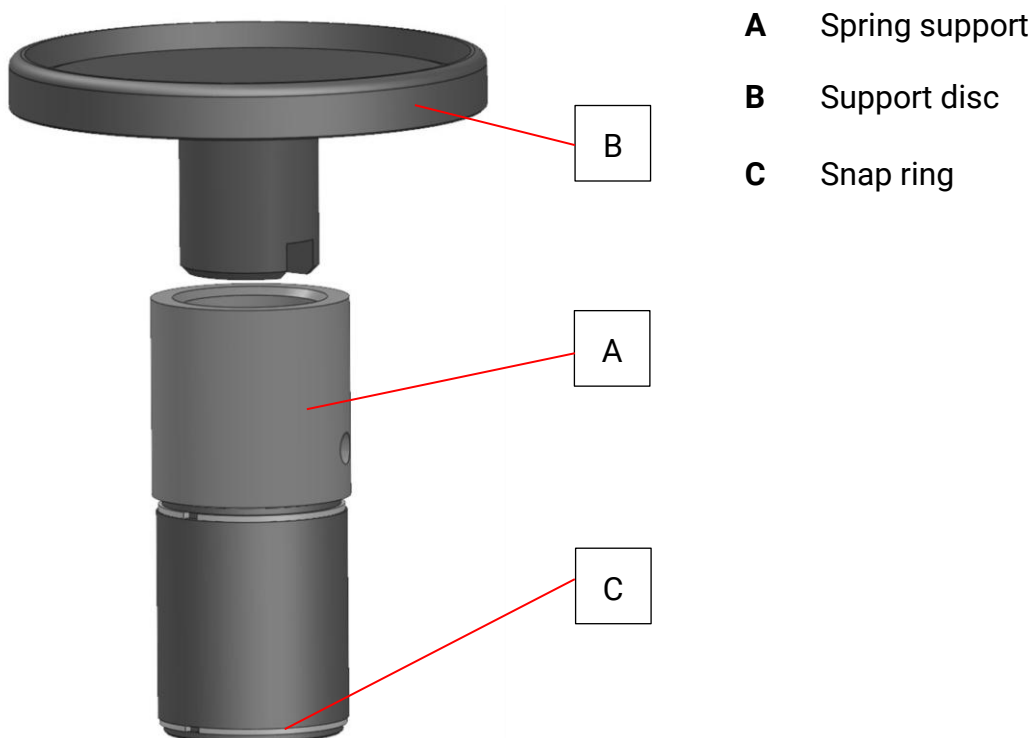

Positioning the support

Compress the spring support with standard support disc with rubber pad or with support arbor, or the spring support with the support disc with granulate coating and a custom ATS adapter, and position it as precisely as possible beneath the lifting points. Slowly release the spring support.



WARNING

Ensure that the groove of the standard support disc with rubber pad, the groove of the support arbor or the groove of the support disc with granulate coating engages with the pin of the spring support.

d. Spring extension support

The threaded insert (A) is screwed into the support arm (standard version).

The standard support disc with rubber pad can be removed and the spring extension (B) can be inserted into the threaded insert (A).

Various supports, such as the standard support disc with rubber pad, the support arbor or the support disc with granulate coating, can now be inserted into this spring extension.

The following steps must be followed for installation:

- 1 The lift is in the initial position; see section “Initial Position/Ready for Operation”.
- 2 Remove the standard support disc.
- 3 Insert the spring extension into the threaded insert. Ensure that the groove in the spring extension engages with the pin on the threaded insert.

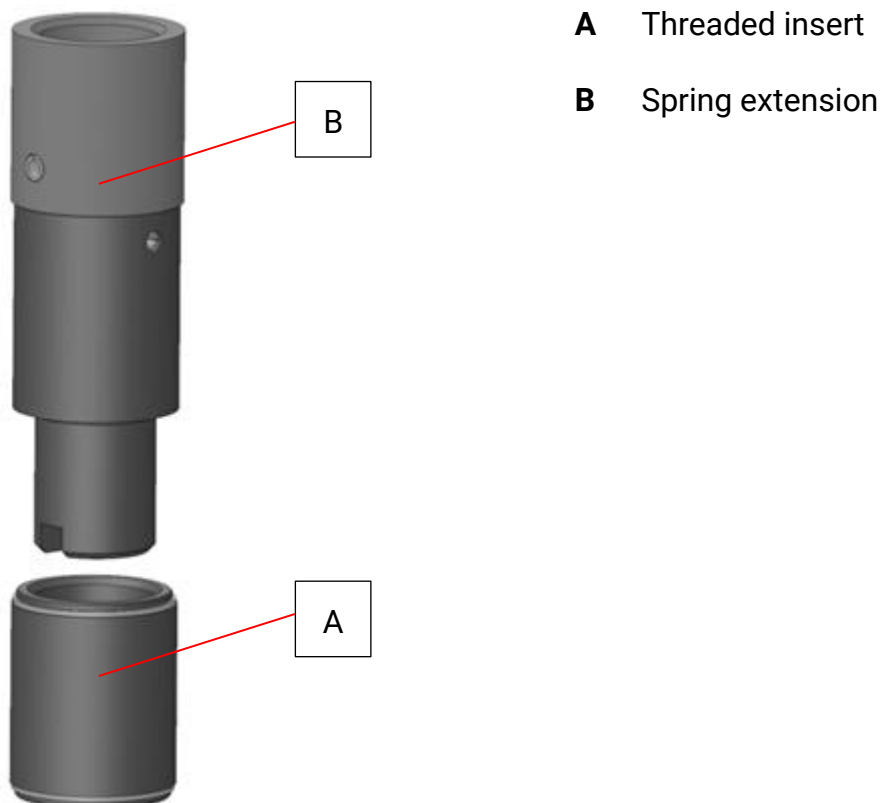

Positioning the support

The spring support extension must only be used with standard support discs with rubber pads, with a support arbor, or with the support disc with granulate coating and a suitable customer-specific ATS adapter. Compress the spring support extension and position it as precisely as possible beneath the lifting points. Slowly release the spring support.



WARNING

- Only **one** spring extension may be used per support arm.
- Ensure that the groove of the standard support disc with rubber pad, the groove of the support arbor or the groove of the support disc with granulate coating engages with the pin of the spring extension.

e. Spring support without locking mechanism with integrated support disc (ATS support)

The spring support without locking mechanism with integrated support disc (A) is screwed into the support arm.

The following steps must be followed for installation:

- 1 The lift is in the initial position; see section "Initial Position/Ready for Operation".
- 2 Remove the standard support disc.
- 3 Remove the upper or lower snap ring from the standard threaded insert.
- 4 Unscrew the standard threaded insert.
- 5 Screw in the spring support without locking mechanism with integrated support disc.
- 6 Secure the threaded insert of the spring support with the snap ring (C).

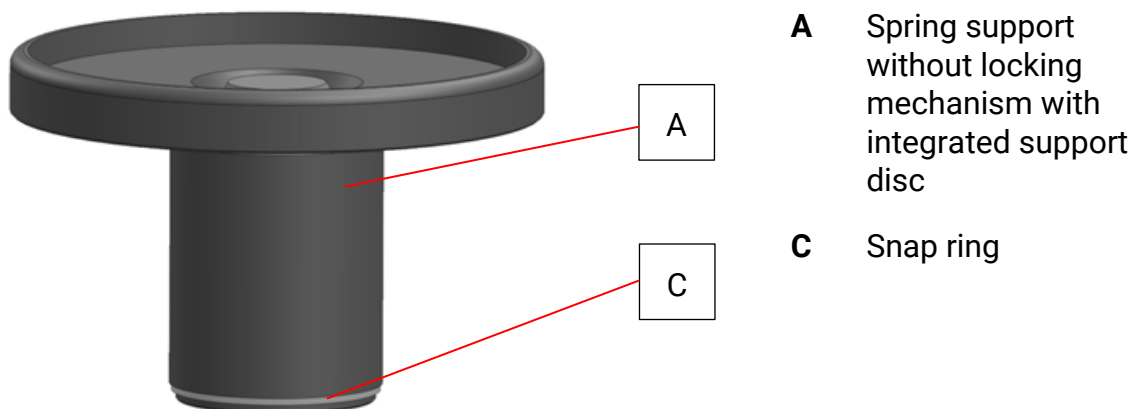

Positioning the support

The spring support without locking mechanism with integrated support disc and with granulate coating must only be used with a customer-specific ATS adapter. Compress the spring support and position it as precisely as possible directly beneath the lifting points. Slowly release the spring holder.



WARNING

Ensure that the snap ring (C) for the threaded insert is fitted.

f. Spring support with locking mechanism and integrated support disc

The spring support with locking mechanism and integrated support disc (A) is screwed into the support arm.

The following steps must be followed for installation:

- 1 The lift is in the initial position; see section “Initial Position/Ready for Operation”.
- 2 Remove the standard support disc.
- 3 Remove the upper or lower snap ring from the standard threaded insert.
- 4 Unscrew the standard threaded insert.
- 5 Screw in the spring support with locking mechanism and integrated support disc.
- 6 Secure the threaded insert of the spring support with the snap ring (C).

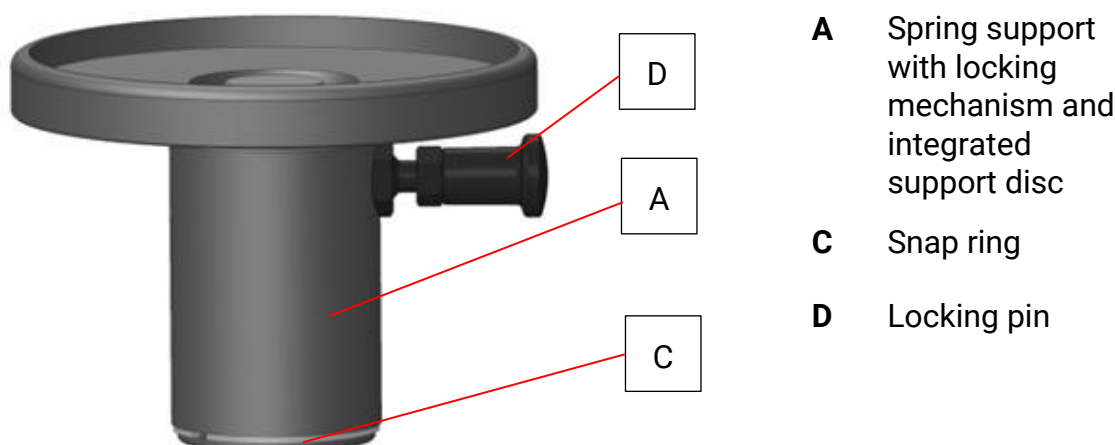

Positioning the support

The spring support with locking mechanism and integrated support disc with granulate coating must only be used with a customer-specific ATS adapter. When using for the first time, compress the spring support until it clicks into place. Position the spring support as precisely as possible beneath the lifting points. Release the locked spring support by pulling the locking pin (D). Lifting the vehicle automatically compresses the spring support until it clicks into place.



WARNING

The spring supports with or without a locking mechanism and integrated support disc (A) must not be used without the snap ring (C) fitted.

g. Supplementary manufacturer-specific load supports (ATS supports)

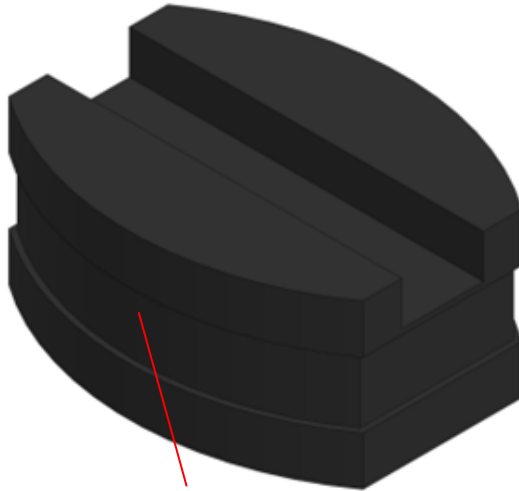

Granulate coating

The oval support PAD with granulate coating shown here serves as an example for all manufacturer-specific special plastic supports.

The manufacturer-specific special supports must be used in accordance with the vehicle manufacturer's application specifications.



Textured surface

The aluminium support PAD shown here serves as an example for all manufacturer-specific special aluminium mounts.

The manufacturer-specific special supports must be used in accordance with the vehicle manufacturer's application specifications.



WARNING

Both the support discs and the manufacturer-specific special supports (ATS supports) must be coated with granulate. Exceptions to this are manufacturer-specific special supports made of aluminium, which have a textured surface on the contact area.

4.6.7 Ceiling Light Barrier



WARNING

Power supply of the ceiling light barrier 230 V AC. Connection only permitted by qualified electrician.

For low ceiling heights, high vehicles or to generate additional safety, an overhead light barrier can be retrofitted to prevent damage to the vehicle and possibly a dangerous situation.

The ceiling light barrier is to be fixed to the hall ceiling with the supplied fixing material. Care must be taken to ensure that possible solar radiation does not hit the reflector. Mount the reflector with its back to the sun if possible.

If the transceiver unit or reflector is mounted so that the light beam is diagonally above the vehicle to be lifted, vehicle superstructures (roof racks, roof boxes, etc.) are also most likely to be detected.

If the ceiling light barrier is triggered during operation, the lifting movement stops and the lift can only be moved away downwards. The behaviour of the ceiling light barrier is identical to reaching the upper end position.

If the ceiling light barrier is triggered without the light beam being interrupted, the reflector and/or the lens may be dirty. In this case, clean the ceiling light barrier with a cloth. Procedure:

- 1 Route the connection cable of the transceiver unit to the control box.
- 2 Connection of the ceiling light barrier by a qualified electrician according to the circuit diagram.

4.6.8 Cable Remote Control



WARNING

Connection only permitted by qualified electrician. The operator is responsible for ensuring that nobody is within the danger area.

A cable remote control is optionally available for the lift. With this it is possible to operate the lift away from the control box. This gives the operator the opportunity to gain improved visibility into the hazardous area.

The cable remote control is generally equipped with the large control element and additionally with an emergency stop button.

Handover of the control

Control box to cable remote control:

Press the F1 and F2 buttons on the control box simultaneously.

Subsequently, control is only possible via the cable remote control.

Cable remote control to control box:

Press the F1 and F2 buttons on the cable remote control simultaneously.

Subsequently, control is only possible via the control box.



When not in use, properly wind up the cable of the cable remote control and store it safely.

5 Troubleshooting

5.1 Safety Instructions



WARNING

- The relevant health and safety regulations must be observed.
- Wear personal protective equipment.
- Service work may only be carried out by authorised service technicians.
- Repairs, maintenance and set-up work should only be carried out when the machinery is stationary. The unit must be disconnected from the power supply and secured against being switched on again.
- Work on the electrical part of the lift may only be carried out by qualified staff or specialist electricians.
ATTENTION: The 230V sockets on the control element(s) also carry current after the system has been switched off!
- Maintenance and repair work should only be carried out when the lift is load-free.
- Only use original replacement parts.
- Substances that are hazardous to the environment must be disposed of appropriately.
- Do not use high or steam pressure equipment or harsh cleaning agents to clean the lift.
- The safety features of the lift must be set by authorised service technicians.
- The safety features must not be replaced or overridden.

5.2 LED Signal Codes

Small control element

LED code			Status/ Note / Error	Remedy
RED	YELLOW	GREEN		
---	---	Lights	Equipment ready for operation	---
Lights	Flashes 3x	---	Inputs (key contact)	Contact MSC*.
Lights	Flashes 6x	---	Liquid detector (optional)	Check the installation box for water ingress and pump it out if necessary. In case of recurrence, contact MSC.
Lights	Flashes 7x	---	Motor temperature	Allow the hydraulic unit to cool down. In case of recurrence, contact MSC.
Lights	Flashes 8x	---	Switch monitoring „CE stop“	Replace roller feeler. In case of recurrence, contact MSC.

*MSC = MAHA Service Center

Large control element

LED code			Status/ Note / Error	Remedy
RED	YELLOW	GREEN		
---	---	Lights	Equipment ready for operation	---
Lights	Flashes 2x	---	Inputs (key contact) internal	Contact MSC*.
Lights	Flashes 3x	---	Inputs (key contact) external	Contact MSC.
---	Lights	Lights	Axle lift not in position	Check position of axle lift. In case of recurrence, contact MSC.
---	Flashes 4x	Lights	Axle lift not in position, below CE stop	Check position of axle lift. In case of recurrence, contact MSC.

LED code			Status/ Note / Error	Remedy
RED	YELLOW	GREEN		
---	Flashes 5x	Lights	Ceiling light barrier (optional)	Remove obstacles in the light barrier. In case of recurrence, contact MSC.
	Flashes 6x	Lights	Liquid detector (optional)	Check the installation cassette for water ingress and pump it out if necessary. In case of recurrence, contact MSC.
---	Flashes 7x	---	Emergency stop switch Remote control (optional)	Unlock emergency stop switch. In case of recurrence, contact MSC.
Lights	Flashes 8x	---	Motor temperature	Allow the hydraulic unit to cool down. In case of recurrence, contact MSC.
Lights	Flashes 9x	---	Switch monitoring "Lift up"	Replace "Lift up" sensor. In case of recurrence, contact MSC.
Lights	Flashes 10x	---	Switch monitoring "CE stop"	Replace "Lift up" sensor. In case of recurrence, contact MSC.
---	---	Lights	Service interval expired	Contact MSC.

*MSC = MAHA Service Center

5.3 Troubleshooting Table

Display	Diagnostics	Remedy
Lighting between runways cannot be switched on.	Fuse F2 defective.	Replace fuse F2, notify MSC*
Lift cannot be fully extended.	Hydraulic oil mantles	Refill hydraulic oil.
Lift raises or lowers jerkily	Air in hydraulic system	Bleed lifting units
Lift does not respond to any keystroke	Main switch off	Switch on main switch
	EMERGENCY STOP switch of the remote control (optional) is actuated	Deactivate EMERGENCY STOP switch
	On-site mains fuse defective.	Replace mains fuse
	Primary fuse F1 of power supply T1 defective	Notify MSC
	Secondary fuse on power supply T1 defective	Notify MSC
	Ceiling light barrier +D-B1 (optional) dirty	Carefully clean the ceiling light barrier
Hydraulic motor starts, but pressure is not sufficient to raise the lift	Pressure relief valve set too low	Notify MSC
	Hydraulic system leaking	Notify MSC
	Hydraulic oil shortage	Check oil level and refill if necessary
	Vehicle too heavy	Observe the load capacity according to the nameplate
Lift with pneumatic lifting floor and axle lift cannot be lowered completely	Axle lift is not in defined end position	Push axle lift into defined end position
	Position switch for defined end position of axle lift defective/misadjusted	Notify MSC

*MSC = MAHA Service Center

6 Inspection

Depending on the conditions of use, the lift must be inspected at intervals of no more than 12 months. In particular, safety devices, fastenings and load-bearing components must be inspected. This inspection must be carried out by a competent person to ensure safe operation also until the next inspection. The inspection and its findings shall be documented.

6.1 Safety Instructions



WARNING

- The relevant health and safety regulations must be observed.
 - Wear personal protective equipment.
 - Service work may only be carried out by authorised service technicians.
 - Repairs, maintenance and set-up work should only be carried out when the machinery is stationary. The unit must be disconnected from the power supply and secured against being switched on again.
 - Work on the electrical part of the lift may only be carried out by qualified staff or specialist electricians.
ATTENTION: The 230V sockets on the control element(s) also carry current after the system has been switched off!
 - Maintenance and repair work should only be carried out when the lift is load-free.
 - Only use original replacement parts.
 - Substances that are hazardous to the environment must be disposed of appropriately.
 - Do not use high or steam pressure equipment or harsh cleaning agents to clean the lift.
 - The safety features of the lift must be set by authorised service technicians.
 - The safety features must not be replaced or overridden.
-

6.2 Daily Inspection before Starting Work

All checks must be carried out with the system in an unloaded condition!

6.2.1 Cables and Actuators

Cables must not show any visible damage. Cables with visible pinch points, damaged sheathing, kinks or clanks must be replaced immediately with new ones.

Pushbuttons must be smooth-running and clean and must not show any damage. Actuated pushbuttons must immediately return to their initial position after being released.

A lift with damaged cables or actuating elements must not be operated!

6.2.2 Emergency Stop

Emergency stop (main switch) and emergency stop (auxiliary control point) disable the drives of the lift in order to bring about a safe state of the system.

For checking, trigger a stroke movement by pressing the button after switching on the control unit. With the button pressed, actuate the emergency stop. The movement of the equipment must come to an immediate stop.

The check must be repeated for all operating points with emergency stop. A system with a defective emergency stop must not be put into operation!

6.2.3 Limitation of the Support Arm Pull-outs

The lift is equipped with telescopic support arms to accommodate a variety of vehicles. To prevent the vehicle from falling, the support arm telescopes are equipped with limits.

For checking, the support arms must be pulled out by hand. The support arms must not jam when reaching the end position, must not have excessive play and must not be able to be levered out upwards.

6.2.4 Limitation of the Support Arm Lock

The support arm lock prevents the vehicle from moving horizontally when raised. To this end, toothed segments are attached to the pivot bearing of the support arms, which allow free movement of the support arms in the lower end position and automatically interlock when lifted.

For inspection, check the locking spindle for free movement and the toothed segments for correct engagement daily before starting work. The toothed segments are correctly fixed when all teeth are fully engaged.

The locking spindles must move smoothly and must not be damaged (bent). Support arm interlocks that do not have the engagement described above, that have broken teeth, or that are otherwise damaged must be replaced immediately in pairs with new segments. The same applies to damaged locking spindles.

6.2.5 Load Supports

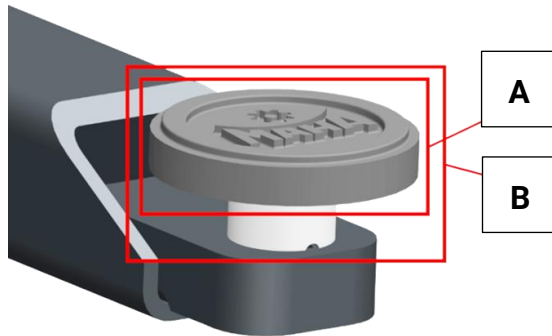

A = Rubber pad

B = Support disc with thread

Support discs take over the load and hold it in position. The rubber pad yields selectively under load. This protects the vehicle's lifting point and prevents the vehicle from slipping. If the rubber pad is damaged, this function can no longer be performed safely. Slipping of the vehicle and a vehicle crash is possible. Support discs must not have any cracks or chipping. Defective support discs must be replaced.

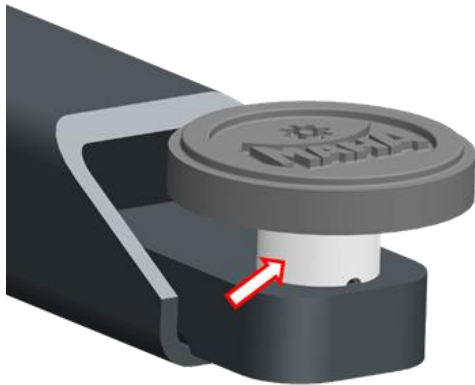

The thread on the support disc is used for height adjustment so that the vehicle rests evenly on all four support discs during lifting. This thread must be smooth-running. Dirty threads should be cleaned and lightly greased. The retaining ring on the underside must be present and correctly fitted.

6.2.6 Piston Rod and Toothed Rack

The piston rods and toothed racks must be visually inspected daily for damage. To do this, the lift must be completely extended and retracted. The two components must not show any damage such as scratches, bumps or signs of corrosion. Damaged piston rods can damage the sealing package and thus lead to leaks in the hydraulic system.

The piston rods must not falter or jerk during extension and retraction.

6.2.7 Pull-out of the Flat Head Support

The vehicle is picked up via the pull-out of the flat head support. The pull-outs can be adjusted at fixed intervals by inserting a grooved pin to adapt to different types of vehicles.

The holes in the pull-out must not be widened or otherwise deformed. The grooved pin must be seated tightly in the locating hole provided. The components must be free of corrosion.

6.2.8 Fastening Screws

The fastening screws of the support structure and the clamping parts on the lifting cylinder guide must be checked daily for tightness.

6.3 Six-Monthly Inspection

6.3.1 Oil Level and Hydraulic Oil

Trouble-free operation of the lift is only possible with functioning hydraulic oil. The hydraulic oil may be non-functional if it has the following characteristics and should then be replaced immediately:

- Turbidity
- Pollution due to solids
- Untypical smell
- Segregation or mixing
- Foaming

Regardless of the aging of the hydraulic oil, the oil level in the hydraulic unit must be checked every six months as follows:

- 1 Lower lift incl. attachments completely.
- 2 Remove the centre cover. For optional floor-level installation, additionally remove the centre cover of the installation frame.

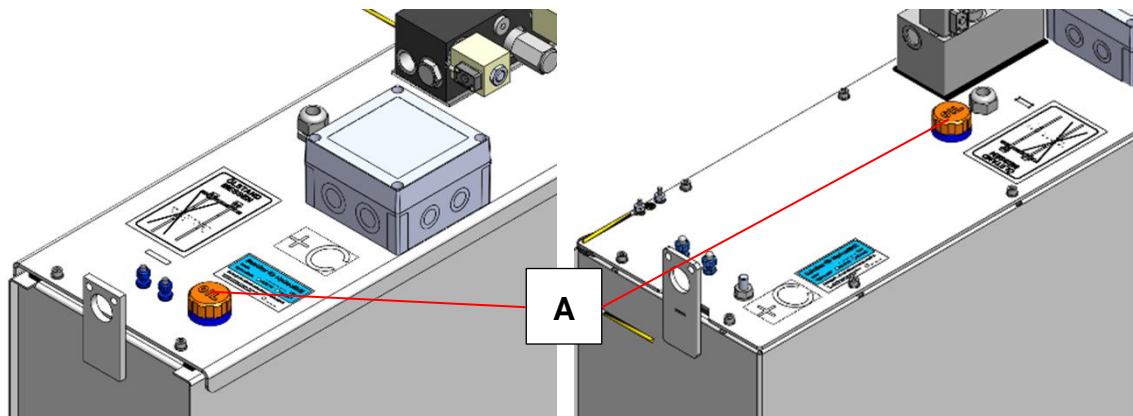

*Detail view of hydraulic power unit
ZS DUETT 3.5 FT*

*Detail view of hydraulic power unit
ZS DUETT 3.5 GS / ZS DUETT 4.5 GS /
ZS DUETT 5.0 GS*

- 3 Unscrew the oil dipstick (A) on the hydraulic unit.

- 4 To measure the oil level, place the dipstick only on the screw fitting, see Fig. The oil level should be between the min. and max. marks.
- 5 If the oil level is below the min. mark, hydraulic oil must be topped up in accordance with the technical data.
- 6 Screw the oil dipstick (A) back in completely.

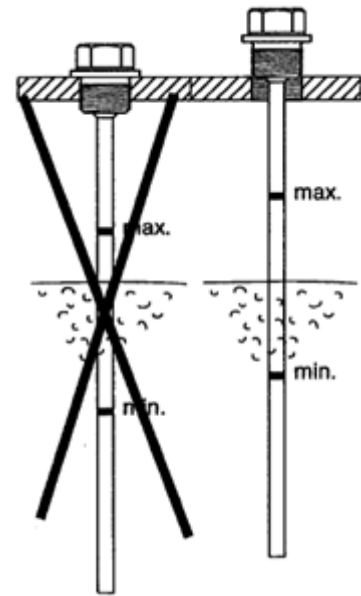

6.3.2 Tightness of the Hydraulic System

All components of the hydraulic system must be checked for leaks. If oil leakage can be detected at the following points, the lift must not be operated any further and the MAHA Service Center must be contacted:

- Floor of the installation box or pit floor
- Wiper ring on the piston rod

In the event of oil leakage at the following points, the screw connections must be retightened to a torque of 45 to 50 Nm:

- Hose fittings/valve fittings on the hydraulic block
- Hose fittings on the lifting units

If oil leakage can still be detected, the lift must not be operated any further and the MAHA Service Center must be contacted.

6.4 Yearly Inspection

There are country-specific requirements for the regular inspection of lifting equipment. These generally require an inspection of the safe operating condition after 12 months at the latest.

Irrespective of these regulations, the following items must be checked at least every 12 months and corrected if necessary.

6.4.1 Welded Joints

All accessible weld seams shall be visually inspected for irregularities, such as cracks or corrosion. In the event of such an irregularity, do not continue to operate the lift under any circumstances. The MAHA Service Center must be contacted immediately.

6.4.2 Tightening Torques

To ensure the stability and function of the lift, all screw connections must be checked and tightened if necessary.

The applicable tightening torques can be found in the technical handbook of the lift.

6.4.3 CE Stop

The CE stop is a programmed intermediate stop approx. 120 mm above the lower end position, which is approached during each lowering process to the lower end position. It alerts the operator to the pinch point between the supports and the floor and gives him the opportunity to make sure that there are no people or tools under the supports.

When lowering, the lifting movement must stop automatically at approx. 120 mm. After releasing and pressing again, it must be possible to move on to the lower end position.

6.4.4 Hydraulic Hose Line

The components of hydraulic hose lines are subject to natural aging. To prevent failure at an early stage, hydraulic hose lines must be checked for at least the following criteria:

- Damage to the outer layer (e.g. scuff marks, cuts, cracks)
- Embrittlement of the outer layer
- Deformations that do not correspond to the natural shape of the hose or hose assembly (both in depressurised and pressurised condition)
- Storage and or use period of the hose

7 Servicing

In order to ensure the safe operation and function of the lift, maintenance must be carried out at the latest after the intervals of the maintenance plan to the extent described.

Maintenance work may only be carried out by specially trained and authorised personnel. Such specialist staff include authorised, trained specialists employed by the manufacturer, the authorised dealers and the relevant service partners.

7.1 Safety Instructions



WARNING

- The relevant health and safety regulations must be observed.
 - Wear personal protective equipment.
 - Service work may only be carried out by authorised service technicians.
 - Repairs, maintenance and set-up work should only be carried out when the machinery is stationary. The unit must be disconnected from the power supply and secured against being switched on again.
 - Work on the electrical part of the lift may only be carried out by qualified staff or specialist electricians.
ATTENTION: The 230V sockets on the control element(s) also carry current after the system has been switched off!
 - Maintenance and repair work should only be carried out when the lift is load-free.
 - Only use original replacement parts.
 - Substances that are hazardous to the environment must be disposed of appropriately.
 - Do not use high or steam pressure equipment or harsh cleaning agents to clean the lift.
 - The safety features of the lift must be set by authorised service technicians.
 - The safety features must not be replaced or overridden.
-

7.2 Lubrication

NOTICE

Only the following lubricants are permitted for maintenance of the lift!

Lubrication point	Lubricant
– Piston rod	Hydraulic oil HLP-D 22 (HLP-D 22 Synth)
– Support arm pull-outs – Threads of support plates – Support arm lock – Pull-outs of flat head supports – Toothed rack	Multipurpose grease

7.2.1 Piston Rod

Rub the entire length of the piston rod daily with hydraulic oil according to the technical data before starting work. The lift must be completely extended for this purpose. Use clean microfibre cloth for thin application and even spreading.

7.2.2 Toothed Rack

The toothed rack must be greased with a multi-purpose grease at least every six months. The lift must be completely extended for this purpose. Use a clean and new brush for application.

7.2.3 Support Arm Pull-outs

The load-bearing arm pull-outs and their optional roller support must be checked for free movement at least every six months and lubricated if necessary.

7.2.4 Support Arm Lock

The toothed segments of the support arm locks must be lubricated every six months at the latest. If necessary, remove coarse impurities from the tooth flanks with a wire brush beforehand.

7.2.5 Flat Head Support Pull-outs

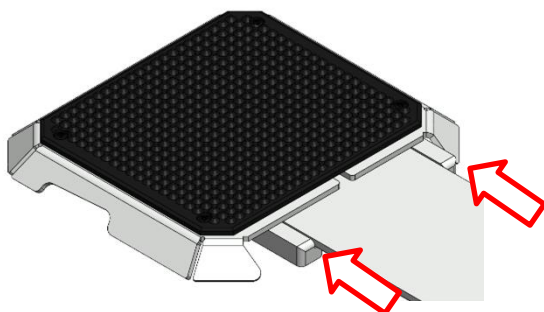

The sliding surfaces of the flat head pull-outs must be relubricated every six months at the latest.

7.3 Hydraulic Hose Lines

NOTICE

Hydraulic hose lines that have already been used must not be used to repair damaged hydraulic hose lines.

In the event of damage of any kind, hydraulic hose lines must be replaced with new ones. In addition, hydraulic hose lines must be replaced after six years at the latest due to aging processes.

7.4 Support Structure Screws

The support structure screws must be replaced every 12 months.

7.5 Bleeding the Hydraulic System



WARNING

Bleeding of the lifting units under load is prohibited.

Air in the hydraulic system can lead to faltering or jerking lifting units. In this case, the two lifting units must be bled as follows:

ZS DUETT 3.5 FT

The lift is in a completely retracted state.

- 1 Extend the lift about halfway.
- 2 Remove the centre cover.



WARNING

Depending on the amount of air in the stroke unit, the piston rod and the support will collapse sharply. Risk of injury!

- 3 Slowly open the hex head screw (A) (A/F 19) in half-turn increments and discharge the air from the lifting unit into the hydraulic power unit.
- 4 As soon as no more air escapes from the lifting unit, tighten the hex head screw (A) (A/F 19) with a tightening torque of 10 Nm.
- 5 Retract the lift completely.
- 6 Check the oil level in the hydraulic power unit and top up with hydraulic oil if necessary.
- 7 Repeat the procedure for the other lifting unit.
- 8 Close the centre cover.

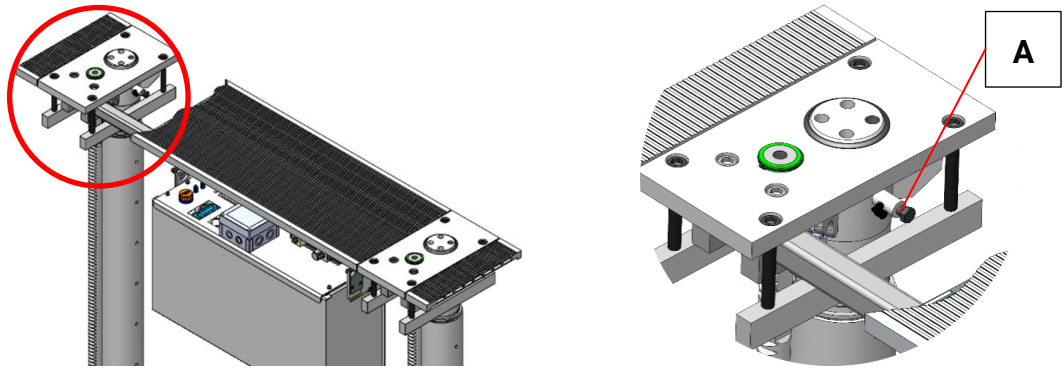

ZS DUETT 3.5 GS / ZS DUETT 4.5 GS / ZS DUETT 5.0 GS

The ZS DUETT 3.5 GS lift must be bled via the lifting units *and* via the piston rods. The ZS DUETT 4.5 GS and ZS DUETT 5.0 GS lift is *only* bled via the lifting units.

Bleeding via the lifting unit

The lift is in a completely retracted state.

- 1 Extend the lift about halfway.
- 2 Remove the sealing plugs (A).



WARNING

Depending on the amount of air in the stroke unit, the piston rod and the support will collapse sharply. Risk of injury!

- 3 Slowly open the threaded pin (A/F 6) located underneath in half-turn increments and discharge the air in the lifting unit into the hydraulic power unit.
- 4 As soon as no more air escapes from the lifting unit, tighten the threaded pin (A/F 6) with a tightening torque of 10 Nm.
- 5 Retract the lift completely.
- 6 Check the oil level in the hydraulic power unit and top up with hydraulic oil if necessary.
- 7 Press the sealing plug (A) back in
- 8 Repeat the procedure for the other lifting unit.

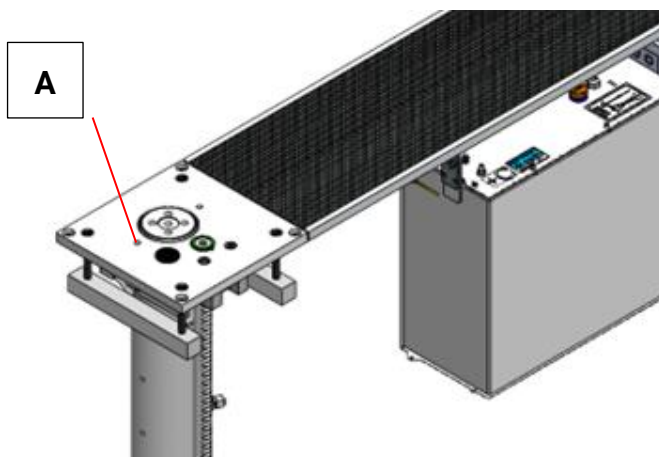

Bleeding via the piston rod

The lift is in a completely retracted state.

- 1 Extend the lift about halfway.
- 2 Remove the middle sealing plug (C) of the respective support.

WARNING

Depending on the amount of air in the stroke unit, the piston rod and the receptacle will collapse sharply. Risk of injury!

- 3 Slowly open the screw plug (D) (A/F 6) underneath in half-turn increments. Take up any escaping oil-air mixture directly with a clean cloth.
- 4 As soon as only hydraulic oil escapes, the lifting unit is bled. Close the screw plug (D) (A/F 6) again with a tightening torque of 10 Nm.
- 5 Retract the lift completely.
- 6 Check the oil level in the hydraulic power unit and top up with hydraulic oil if necessary.
- 7 Press the sealing plug (C) back in.
- 8 Repeat the procedure for the other lifting unit.

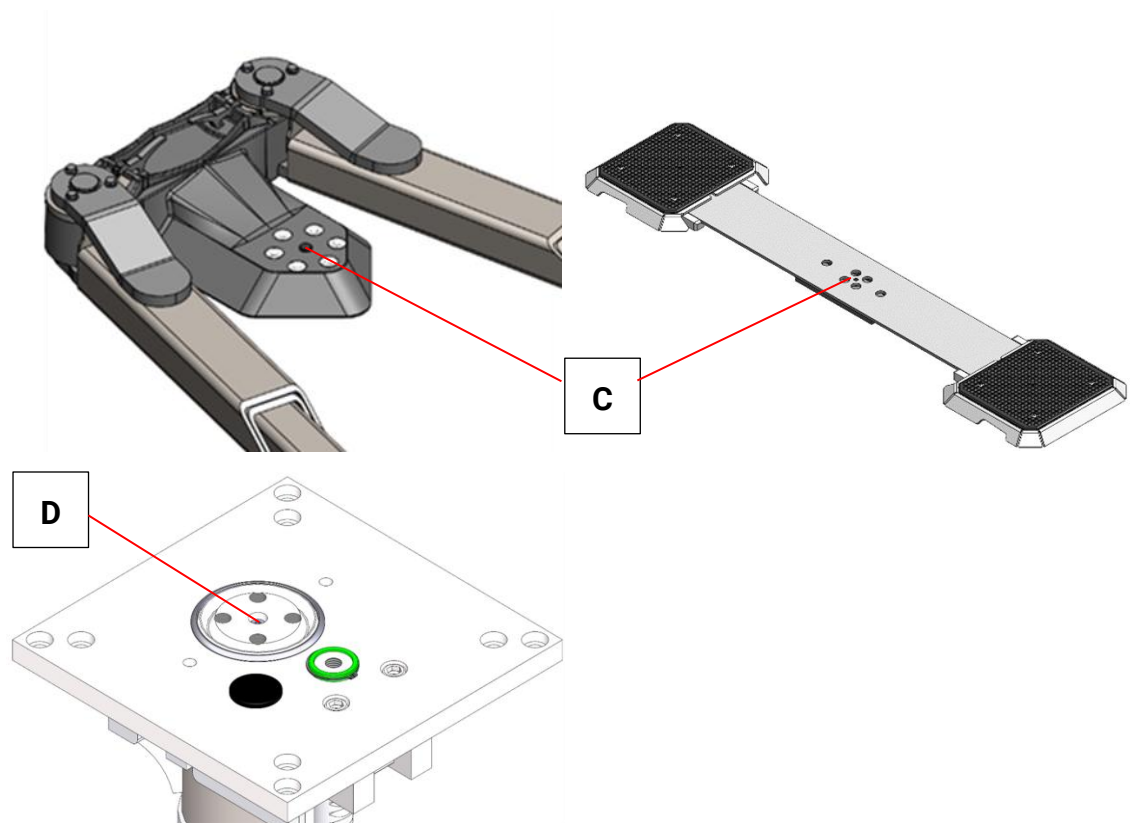

8 Care Instructions

NOTICE

- Any damage to the paintwork should be repaired immediately to prevent corrosion.
 - To prevent damage, cleaning work must not be carried out with harsh cleaners or with high and steam pressure equipment.
-

9 Repairs

NOTICE

See repair instructions in the technical handbook of the lift.

10 Decommissioning, Dismantling and Disposal

The device may only be taken out of operation and disassembled by specially authorised and trained personnel. Such specialist staff include authorised, trained specialists employed by the manufacturer, the authorised dealers and the relevant service partners.

Observe the product and safety data sheets of the lubricants used. Avoid environmental damage. If the device is to be disposed of, it must be disposed of in an environmentally responsible manner in accordance with local legislation. Sort all dismantled materials according to type and take them to a suitable recycling point. Collect operating materials such as grease, oil, coolant, cleaning fluids containing solvents etc. in suitable containers and dispose of them in an environmentally responsible manner.

Alternatively, you can take your device to a waste management company. They will ensure that all parts and fluids are disposed of properly and ecologically.

11 Declaration of Conformity

See following page(s).



**Original-EG-Konformitätserklärung
Original EC Declaration of Conformity**

CE320301-de-en



MAHA SE & Co. KG

erklärt hiermit als Hersteller in alleiniger Verantwortung, dass nachstehend bezeichnetes Produkt in Konzeption und Bauart den grundlegenden Sicherheits- und Gesundheitsanforderungen der hier genannten Richtlinien entspricht.

Bei Änderungen am Produkt, die nicht von oben genannter Firma genehmigt wurden, verliert diese Erklärung ihre Gültigkeit.

herewith declares as a manufacturer its sole responsibility to ensure that the product named hereafter meets the safety and health regulations both in design and construction required by the directives stated below.

This declaration becomes void if any change is made to the product that was not approved by named company beforehand.

Typ | Model

ZS DUETT

Serialnummer | Serial Number

Bezeichnung | Designation

Zwei-Stempel-Hebebühne

Two Post Inground Lift

Richtlinien | Directives

2006/42/EG

2014/30/EU

2011/65/EU

2006/42/EC

2014/30/EU

2011/65/EU

Normen | Standards

DIN EN 1493

DIN EN 60204-1

Bevollmächtigter für die Zusammenstellung der technischen Unterlagen

Person Authorised to Compile the Technical File

Ralf Kerkmeier · MAHA SE & Co. KG · Hoyen 20 · 87490 Haldenwang · Germany

Haldenwang, 2026-03-01

Dr. Peter Geigle

Geschäftsführer | Managing Director

